

Umbrella Arch Nomenclature and Selection Methodology for Temporary Support Systems for the Design and Construction of Tunnels

Jeffrey Oke, Nicholas Vlachopoulos & Vassilis Marinou

Geotechnical and Geological Engineering

An International Journal

ISSN 0960-3182

Volume 32

Number 1

Geotech Geol Eng (2014) 32:97-130

DOI 10.1007/s10706-013-9697-4

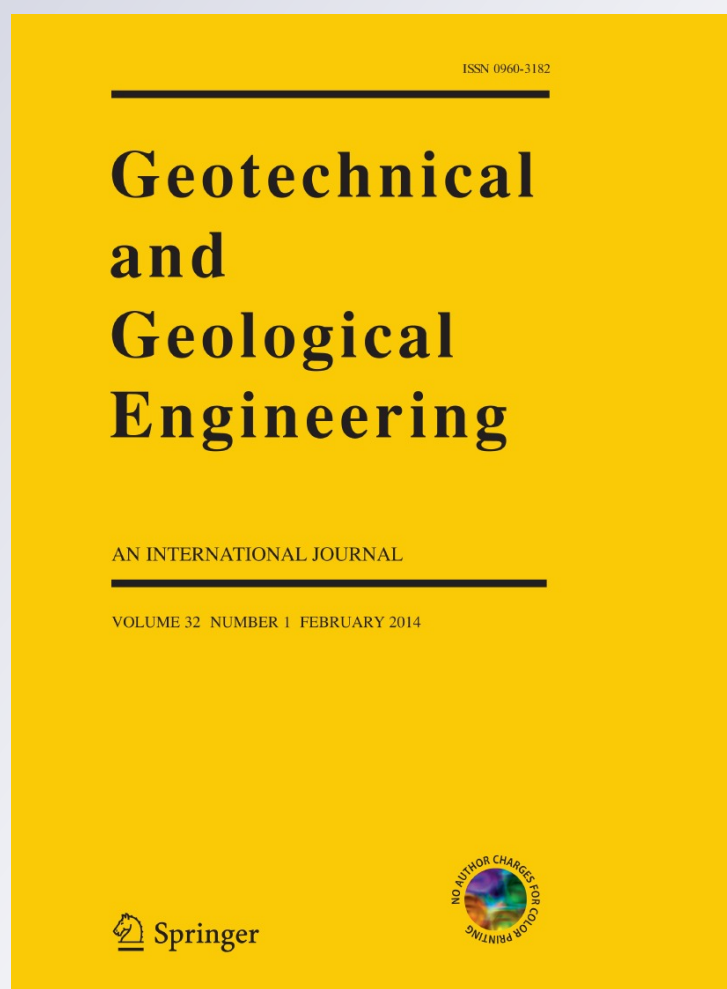

 Springer

Your article is protected by copyright and all rights are held exclusively by Her Majesty the Queen in Right of Canada. This e-offprint is for personal use only and shall not be self-archived in electronic repositories. If you wish to self-archive your article, please use the accepted manuscript version for posting on your own website. You may further deposit the accepted manuscript version in any repository, provided it is only made publicly available 12 months after official publication or later and provided acknowledgement is given to the original source of publication and a link is inserted to the published article on Springer's website. The link must be accompanied by the following text: "The final publication is available at link.springer.com".

Umbrella Arch Nomenclature and Selection Methodology for Temporary Support Systems for the Design and Construction of Tunnels

Jeffrey Oke · Nicholas Vlachopoulos ·
Vassilis Marinos

Received: 26 April 2013 / Accepted: 10 September 2013 / Published online: 27 September 2013
© Her Majesty the Queen in Right of Canada 2013

Abstract This paper argues that there is a requirement for standardized nomenclature and a selection methodology for a particular class of temporary support. The authors have chosen the term Umbrella Arch (UA) to define the method of support that acts as pre-support that is installed during the first pass of the excavation around and above the crown of the tunnel face. The UA supports the rock mass and the tunnel face predominately by transferring loading longitudinally through the interaction of the support and surrounding ground condition. There are three categories of UA. Categorization depends on the type of support element used. These elements include: (1) Spiles; (2) Forepoles; and (3) Grouted. These categories can be further divided into 11 sub-categories quantified by the amount of grout utilized in the installation. The sub-categories are justified by the employment of each sub-category within a support selection methodology for an UA; this was created by the authors based on experience and through a comprehensive literature search that included published papers as well as design reports. The collection of publications has resulted in 141 permutations of

different temporary tunnel support in varying weak and difficult geological condition. The UA support selection methodology was created to aid tunnel designers in these conditions with the basic concepts for the appropriate selection process for an UA. Furthermore, the authors quantified the support selection methodology through the employment of other pre-existing design charts and empirical evidence to create a new design tool, the UA selection chart. Overall, this paper hopes to achieve the creation of an international standard with respect to UA and UA support element nomenclature and a better understanding for the selection of a particular UA sub-category.

Keywords Umbrella Arch · Forepole · Spile · Grout · Tunnel behaviour chart · Weak rock · Temporary rock support and tunnelling

1 Introduction

Varying geological conditions can lead to complications with respect to underground works and tunnelling excavations. Weak rock masses (or granular material with low cohesion) that are encountered during excavation (whether foreseen or unexpected) can require additional and ingenious means of temporary support measure to prevent failure of the

J. Oke · N. Vlachopoulos (✉)
GeoEngineering Centre, Queen's-RMC, Kingston, ON,
Canada
e-mail: vlachopoulos-n@rmc.ca

V. Marinos
Faculty of Sciences, School of Geology, Aristotle
University of Thessaloniki, Thessaloniki, Greece

ground. Pre-support (Sadaghiani and Dadizadeh 2010) (pre-confinement (Lunardi 2008), auxiliary method (Kimura et al. 2005), and pre-improvement (Song et al. 2006), is an additional means of initial, temporary support utilized in tunnel construction when there is a requirement for support ahead of the tunnel face. Pre-support is divided into two fundamental methods: (a) face support and, (b) support added in the vicinity of the crown above the face (Fig. 1, yellow region). While the debate between these two pre-support methods has generated interest in the tunnelling community, identification of the superior method is outside the scope of this paper. This paper focuses on the pre-support in the locality above the face at the crown of a tunnel excavation (category b) strictly during the first pass of the excavation (or at the portal). Pre-support installed from the surface, from adjacent excavations, and within or around a pilot tunnel are outside the scope of this paper. Additionally, the pre-support schemes investigated provide reinforcement by strengthening the surrounding geological material through the interaction between the support elements installed and the soil/rock mass. An in-depth literature review of relevant methods of crown support reveals a complicated and confusing use of terminology that describe relatively the same fundamental support types by function. The authors have accepted the general term of the temporary support arrangement (category b) as an Umbrella Arch (UA) (Appendix 1) that encompass the following exhaustive list of support elements within the terminology cited in literature: Forepole (Hoek 2007), pipe roofing (Gamsjäger and Scholz 2009), pipe roof support (Volkman and Schubert 2007), pipe roof umbrella, steel pipe umbrella, UA method (Ocak 2008), umbrella vault (Leca and Barry 2007) long span steel pipe fore-piling (Miura 2003), steel pile canopy (Gibbs et al. 2007), sub-horizontal jet-grout columns (Coulter and Martin 2006) canopy technique: jet-columns (Croce et al. 2004), and Spiles (Sp) (Trinh et al. 2007; Hoek 2007). Further investigation reveals that for each of the previously listed temporary support elements there are noted differences in their use, application and/or interaction with the soil/rock mass (i.e. in terms of stiffness and grout). The UA definition alone does not address the usage and functional differences of the cited terminologies. Additional categories are warranted to further filter the terminology. However, selected terminologies commonly used

in literature are loosely defined, resulting in conflicting categories (further explained in subsequent sections). Therefore, a standardized nomenclature of support types is warranted in order to ensure that tunnelling engineers and relevant practitioners communicate effectively and adhere to an accepted universal standard. These categories and sub-categories are presented herein as a standardized nomenclature for these support types.

To further organize and differentiate between the various temporary support sub-categories that exist within the standardized nomenclature presented herein, the authors also introduce a support selection methodology for an UA based on geological features, anticipated/observed failure mechanisms, impact of water presence, as well as relevant, in situ considerations. This support selection methodology will aid the tunnel design engineer selection of the type of UA sub-categories under certain conditions. This support methodology has been further quantified within the herein, developed Umbrella Arch Selection Chart (UASC) that is substantiated primarily by relevant UA applications cited in literature data, and with other design charts. As such, the UASC (and the antecedent design methodology) that has been developed in this paper has been empirically and numerically substantiated; empirically verified using 141 cited publications (and design reports) of tunnels that utilized such support schemes in various geological conditions and numerically supported through additional literature review that captures the improvement trends, from numerical analysis, of subsidence under different geological conditions and UA support systems.

2 Background

The design parameters associated with the support elements consist primarily of: length (L), angle of installation, overlap of successive UAs, spacing between support elements, diameter of support elements (Fig. 1), and grouting pressure. Selected researchers (Song et al. 2006) have attempted to optimize selected design parameters of UAs. However, without a clear determination of when to utilize a certain support type within certain ground conditions, optimization of temporary support element arrangements is not possible. As such, investigating pre-existing UA support systems employed in tunnelling

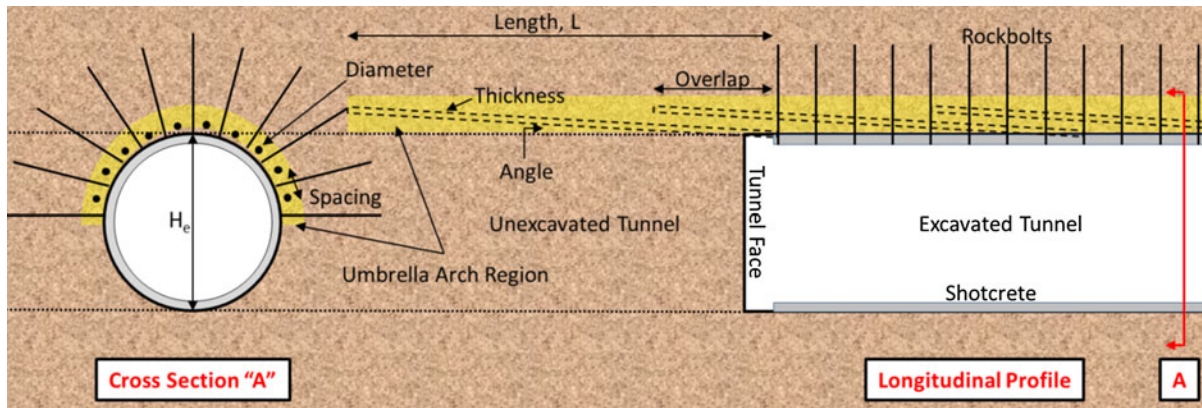

Fig. 1 Umbrella Arch design parameters, illustration of a Forepole confined Umbrella Arch. The yellow shaded region defines the applicable zone of where the Umbrella Arch is

installed (category b). The other pre-support (category a) is installed within the unexcavated tunnel zone only. H_e height of excavation

Table 1 Example of conflicting nomenclature of Umbrella Arch support elements and design parameters

	Typical reference excavation type: metro tunnel ($H_e = *6.87$ m) (Tuncdemir et al. 2012)	Typical reference excavation type: highway tunnel ($H_e = *8.85$ – $*14$ m) (Wittke et al. 2006)
$L < H_e$	<i>Forepole</i>	<i>Spiles</i>
Length	3–4 m (sometimes 5 m)	3–6 m (12 m if grout injected)
Angle	5°–10°	5°–15°
Overlap	1/4–3/4 of length (generally 1/2)	0.8–1.2 m
Spacing	No reference	Max 30 cm
Size	32–38.1 mm	25–28 mm
$L > H_e$	<i>Umbrella Arch</i>	<i>Pipe umbrella</i>
Length	9–16 m	15–30 m
Angle	6°–8°	–5°
Overlap	1/4–3/4 of length (generally 1/2)	Min 3 m
Thickness	*3.65 mm	8–25 mm
Spacing	*30 cm	30–50 cm
Size	114 mm	76–200 mm

H_e height of excavation

* Not generalized values, values from selected authors published case studies

projects around the globe in different geological conditions has provided very real insight into the relevance of a particular support element for certain conditions. In addition, the investigation found that the nomenclature of the support elements utilized in

tunnelling projects around the globe that are of similar function and have similar design parameters must be standardized. An example of an attempt at optimization of support elements without a standardized or clear definition can be seen within Song et al. (2006). Song et al. (2006) conducted a parametric analysis by varying the design parameters of UA support elements. The parametric analysis consisted of (but was not limited to) varying the diameter of the tunnel and the length of the support elements from 10–30 to 6–18 m respectively. Even though the parametric analysis captured the positive trends, with respect to convergence, of an increase in the length of the support, Song et al. (2006) did not address the condition of a support length (L) less than the height of the tunnel excavation (H_e). Many researchers have distinguished the two types of support element lengths: a length smaller than the tunnel excavation height ($L < H_e$); and a support element length larger than the excavation height ($L > H_e$) (Miura 2003; Peila and Pelizza 2003; Volkmann and Schubert 2006; Leca and Barry 2007; Wittke et al. 2006; Tuncdemir et al. 2012; Fang et al. 2012). A comparison of support elements (Table 1) illustrates the existence of two types of supports that exist in literature based on the work of Tuncdemir et al. (2012) and Wittke et al. (2006).

It is evident that the support types and dimensions included in Table 1 cause some confusion in terms of naming supports. A clear design parameter that divides both of the referenced authors' definitions in Table 1 is the support length. In general terms, what

Tuncdemir et al. (2012) define as a Forepole, Wittke et al. (2006) name as a Spile. Further, for similar functions, the cited authors use dissimilar terms for similar support functions; one uses UA while the other uses Pipe Umbrella. The smaller supports (Forepole and Sp) have a length of support smaller than typical excavation height referenced. Similarly the larger supports (UA and Pipe Umbrella) have a length of support greater than the typical excavation height referenced. Furthermore, a comparison of the other design parameters of Table 1, Forepoles (Fp) and Sp are generally installed at greater angles, smaller size, and with closer spacing than the larger UA and Pipe Umbrella elements. These differences exist because the selection of shorter support elements is usually based on structural (geological) failure type and/or availability of proper installation equipment. The selection of longer support is commonly based on preventing complete failure of the tunnel face, or to minimize the convergence of the tunnel in order to minimize surface settlements. Therefore, the failure mechanism and the risk of convergence will dictate the appropriate composition of the UA support elements.

As previously stated, standardized nomenclature is required, with respect to the use of the appropriate support elements as part of the UA, in order to properly address a variety or expected geological failure modes. This standardization will serve to regulate terminology and prevent conflicting technical terms associated with temporary support elements that constitute an UA. An example of such conflicting terminology is evident in the works of Hoek (2007) and Tuncdemir et al. (2012). The respective publications utilize the same terminology in order to define two, separate support arrangements. Hoek (2007) refers to the smaller supports as Sp, and the larger supports as Fp, while Tuncdemir et al. (2012) refer to the smaller supports as Fp, and the larger supports as an UA. Hoek (2007) states that the length of a Forepole is typically 12 m, while Tuncdemir et al. (2012) state the typical length is 3–4 m. The discrepancies that currently exist with regards to the definitions of such support elements may, potentially (yet critically) not perform with the same mechanical behaviour of the support element-rock mass/soil interaction (i.e. support element choice has a range of length and stiffness that affect its performance and mechanical behaviour). Hence, without a

requirement for a standardization of terminology, conflict of terms could arise which could lead to confusion when communicated amongst engineers and when handled by construction project personnel within the context of international collaborations. The resulting lack of clarity could also lead to wasted resources (mainly cost) for both the contractors and their clients.

Other publications have attempted to rectify the other related discrepancies through a classification based on the differences and similarities of certain support schemes. An example of such a classification can be found within the works of Peila and Pelizza (2003) as summarized in Table 2. Peila and Pelizza (2003) listed the most common ground reinforcement techniques that provide improvement, reinforcement, pre-support, and drainage past the tunnel face (i.e. into the rock mass in front of the tunnel face). However, Table 2 only lists the division of support elements with respect to the generalized geological material conditions. Factors involving impact at the subsidence, water conditions, and type of failure conditions have not been taken into consideration; key mechanisms that must be taken into account at the design stage. The findings of this paper further expands the classification of interventions a–c (in Table 2) of Peila and Pelizza (2003) in isolation and/or in combination with each other. The other methods cited in Table 2 (i.e. d–h) have not been investigated as their techniques are not a first pass construction-type system and/or do not take into consideration strengthening and interaction between the support installed and the surrounding geological material. Additional methods exist that have been classified as pre-support but are not included within Table 2. These methods have been employed in tunnelling works in difficult terrain and are often compared to an UA method. However some of these methods fall outside the scope of an UA, they are included herein in order to distinguish and further clarify the definition of the UA as defined by the authors (Appendix 1). For clarification, the definition of the UA, as defined by the authors, is a pre-support method that is installed during the first pass of excavation from within the tunnel, above and around the crown of the tunnel face, that reinforces through the interaction of support and the rock mass/soil. The three categories and ensuing 11 sub-categories of an UA will be explained in subsequent sections and summarized in Appendix 1.

Table 2 Field of applicable for different types of intervention (modified after Peila and Pelizza 2003)

Type of Intervention	Field of application				
	Cohesive terrain	Sandy/gravelly terrain	Terrain with boulders	Fractured rock	Complex Formation
<i>Investigated methods</i>					
a) Grouting	1	X			
b) Jet-grouting	2	X	3		
c) Umbrella Arch	X	4	X	X	X
<i>Non-investigated methods</i>					
d) Fibreglass elements	X	5		6	
e) Pilot tunnel precut	X	X	X	X	X
f) Pre-tunnel	X	X		X	
g) Freezing		X	X		
h) Dewatering	7	X	X	X	

The interventions listed in this table can be combined in order to guarantee safe tunnelling conditions in almost all geotechnical conditions. Grouting, jet-grouting, freezing and dewatering can be normally be applicable also when tunnelling under water table. The other interventions when the tunnel is under the water table must be combined with impermeabilization techniques

1 Chemical grout, 2 two or three fluid jet grouting, 3 steel rebar or pipe reinforced jet grouting, 4 additional grouting, 5 additional grouting, 6 high resistance element, 7 active dewatering (vacuum pump required)

2.1 Other Pre-support Methods

There is an abundance of varying methods of temporary support about the crown that do not fall under the definition of the UA (Appendix 1) (Schumacher and Kim 2013, Sadaghiani and Dadizadeh 2010; Leca and Barry 2007). Selected authors have erroneously compared cited support methods to an UA or have suggested that these methods belong within the within the classification of an UA. Examples resulting in such possible misclassifications are: the Concrete Arch Pre-Supporting System (CAPS) and pre-vault methods. These methods are the focus of the sub-sections below.

2.1.1 Concrete Arch Pre-supporting System (CAPS)

CAPS is the process of creating side audits of pre-existing tunnels, which can then be used to excavate arches above the existing tunnels (see Fig. 2). Subsequently, these arches are further reinforced to provide protection of the unexcavated zone. In Sadaghiani and Dadizadeh (2010) a new method of CAPS is purported to be superior to using an UA. Sadaghiani and Dadizadeh (2010) state that CAPS is generally more cost and time effective when compared to Forepoling and Grouting pre-support systems. An important consideration, however, is that the CAPS system is primarily used for large-span underground

excavations, such as in the expansion of existing tunnels into underground caverns (i.e. underground metro stations). It is not, however, a first pass method which is a stipulation of the definition.

2.1.2 Pre-vaults

Pre-vault or Forevault is another method that falls outside of the scope of this paper but has been include for completeness as it is an at or above face method that is utilized. This method does not strengthen the rock mass or include support/rock mass interaction. Instead, the method cuts out a 15–30 cm thick portion of the rock sub-parallel to the tunnel from the face to a max depth of 5 m (Leca and Barry 2007). The void created is then filled with shotcrete, creating a shell-like structure similar in shape to the UA arrangement as shown in Fig. 3.

2.2 Umbrella Arch Categories

The UA is most often employed within conventional tunnelling approaches. Its application however, is not limited to conventional tunnelling techniques, as it has also been employed in conjunction with tunnel boring machines (TBM). An example of such an application is the open TBM that was used as part of the Niagara Hydroelectric Tunnel, Niagara Falls, Ontario, Canada

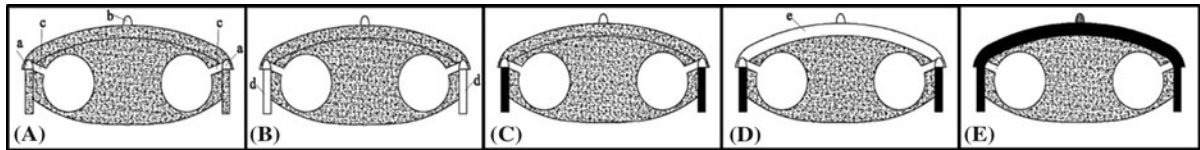
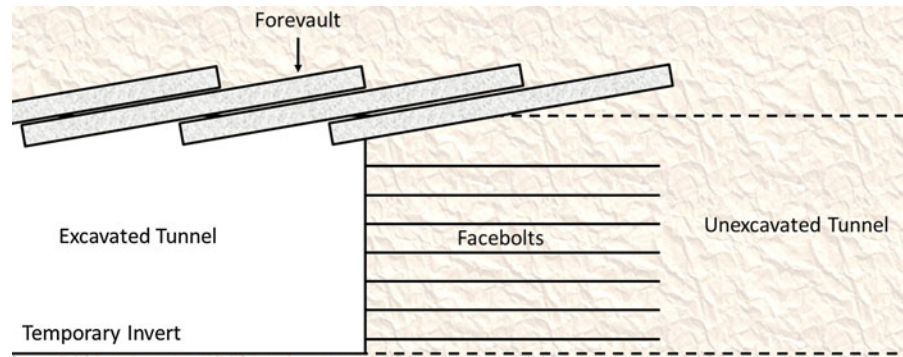

Fig. 2 CAPS sequence of construction (modified after Sadaghiani and Dadizadeh 2010). **A** Side and top audit excavation. **B** Side pile foundation excavation. **C** Construction of side pile foundations. **D** Excavation of arch. **E** Construction of support arch

Fig. 3 Principle of the pre-vault technique (modified from Leca and Barry 2007)



(Gschnitzer and Goliasch 2009). The UA support can be further divided into three different categories based on the support elements used. These support elements are divided by their physical properties. These subcategories consist of: Sp, metallic longitudinal members that are shorter than the height of the tunnel (H_c); Fp, metallic longitudinal members that are longer than H_c ; and Grouted (G), an UA element that simply consists of grout. The main contrast between Sp, Fp, and Grouted are that the systems vary in their respective stiffness, costs, and time commitment for installation if used within their applicable ranges (Volkman and Schubert 2007, Tuncdemir et al. 2012). These categories are in agreement with Fang et al. (2012); however, Fang et al. (2012) uses different terminology for these categories. The terminology presented in this paper is based on other authors (example: Hoek (2007), and industry (example: Dywidag-Systems International (2012)) nomenclature that has been previously utilized and accepted. Further explanations of the three different categories and ensuing sub-categories are found in the subsequent sections. An illustration of the UA sub-categories and their associated range of design parameters (according to an extensive literature review) are shown in Table 3. Furthermore, Table 3 also states the number of associated case study publications for each sub-category (in brackets) as well as the selected range of

design parameters and geological conditions for each sub-category. Table 3 also includes additional abbreviations [confined (C), double (d), continuous (c) and open Grouted (o)] used in conjunction with the previously defined abbreviations to name the sub-categories of the UA. These abbreviated names have been illustrated in Fig. 4 and will be further elaborated upon in subsequent sections.

2.2.1 Spiles

Spiles are classified as longitudinal supports with a length measuring less than the H_c . Sp are habitually installed when the geological structure itself controls a possible local failure of the portion of the tunnel (Volkman and Schubert 2006). Furthermore, Sp are inserted at a range of angles of 5° – 40° to the horizontal plane of the longitudinal axis of the tunnel excavation in order to attempt to achieve adequate structural control and proper embedment (Vardakos 2007). It is suggested that the center to center spacing of Sp be <30 cm. In addition, such spacing is stipulated as a safety requirement which protects the workers from spalling/ravelling or large wedge type failures from falling between the individual support elements. The overlap of the Sp is directly linked to the potential problematic reoccurring rock mass structure that may be present within the tunnel profile. Typically, the

Table 3 Divisions of Umbrella Arch and the associated range of case data design parameters

Umbrella Arch (141)		Forepole (56)					GROUT(9)			GROUT (15)	
Spile (31)		GROUT(1)					GROUT(9)			GROUT (15)	
		Forepole (1)					Forepole (23)			GROUT (6)	
SpCUA (4)		SpGUA (14)	SpGcUA(1)	FpCUA (1)	FpGUA (23)	FpdGUA (2)	FpGoUA(1)	FpGcUA (2)	FpGdcUA (6)	GoUA (0)	GcUA (6)
<i>Range of Umbrella Arch design criteria</i>											
Length	<H _e	<H _e	<H _e	>H _e	>H _e	>H _e	>H _e	>H _e	>H _e	>?H _e	>H _e (<6H _e)
Angle (°)	5–16	5–10	10–20	?3–5	3–8	~3	?	~5	~11	?	6–11
Overlap (m)	1–4.5	1–6	2–3	<L/2	<L/2	>L/2	<L/2	<L/2	>L/2	?	1–3
Spacing center-to-center (cm)	20–50	25–50	60–100	35–60	30–60	30–30.5	~50	50–60	40–76	?	40–45
Diameter (mm)	25–50.8	25–101.6	~27.5	~114.3	50–325	101.6–114	~114 (*?)	114.3	89–168.3	?	*500–970
*Grout penetration	NA	~1	*~>1 m	NA	0.20–1	0.21–0.41	?	?	(*>spacing-800)	?	35–50
<i>Range of geological consideration</i>											
Overburden	(1.35–6.67)H _e	(0.31–7.63)H _e	?	(~2.15)H _e	(0.45–30)H _e	(0.36–2.86)H _e	(~2.53)H _e	(0.52–2.87)H _e	(0.36–7.50)H _e	?	(0.59–3.5)H _e
GSI	25	20–35	20–35	?	20–45	20–35	RQD (0–17 %)	?	?	?	?
Cohesion (kPa)	7.5–70	7.5–200	?	?	0–500	~80 (residual ~30)	?	~15	0–50	?	0–20
Internal friction angle (°)	21–27	24–33	?	?	20–36	~32 (residual ~26)	?	30	20–37	?	30–40
Water table [distance from top of crown] (m)	?	18–0 m	~>41 m	?	~6 to ~4 m	?	12.7–21.7	16.5–21	Below invert to ?high?	?	–3 to?
Permeability (cm/s)	?	?	1.3–1.7 × 10 ⁻⁵	?	1.0 × 10 ¹⁻ 2.9 × 10 ⁵	?	?	1.0 × 10 ²⁻ 2.9 × 10 ⁵	?	?	?

~ Only value sourced, XX–XX range of data, ? : no direct value referenced, XX published cases, H_e height of excavation, NA not applicable, L length of support

SpGUA Spile GROUT Umbrella Arch, SpCUA Spile Confined Umbrella Arch, SpGcUA Spile Continuous GROUT Umbrella Arch, FpCUA Forepole Confined Umbrella Arch, FpGUA Forepole GROUT Umbrella Arch, FpdGUA Double Forepole GROUT Umbrella Arch, FpGoUA Forepole Open GROUT Umbrella Arch, FpGcUA Forepole Continuous GROUT Umbrella Arch, FpGdcUA Forepole Double Continuous GROUT Umbrella Arch, GoUA Open GROUT Umbrella Arch, GcUA Continuous GROUT Umbrella Arch

Fig. 4 Illustration of the nomenclature for the Umbrella Arch method of pre-support. *SpGUA* Spile Grouted Umbrella Arch, *SpCUA* Spile Confined Umbrella Arch, *SpGcUA* spile Continuous Grouted Umbrella Arch, *FpCUA* Forepole confined Umbrella Arch, *FpGUA* Forepole Grouted Umbrella Arch, *FpdGUA* Double Forepole Grouted Umbrella Arch, *FpGoUA* Forepole Open Grouted Umbrella Arch, *FpGcUA* Forepole Continuous Grouted Umbrella Arch, *FpGdcUA* Forepole Double Continuous Grouted Umbrella Arch, *GoUA* Open Grouted Umbrella Arch, *GcUA* Continuous Grouted Umbrella Arch

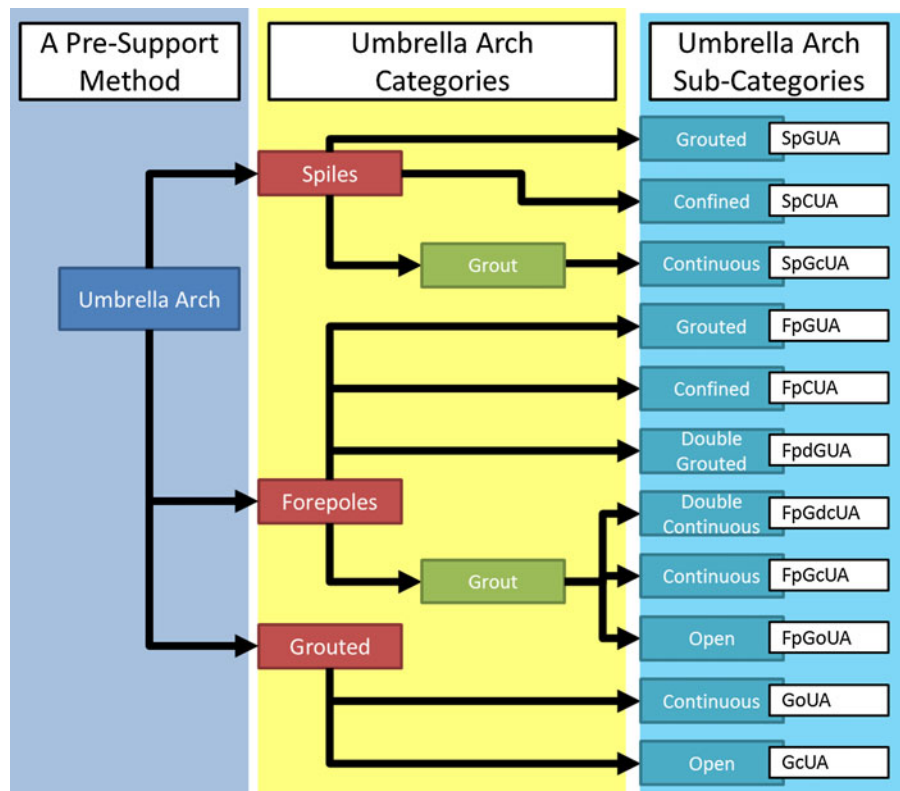

overlap is half of the overall Spile length but ranges from 1/3 to 2/3 of the Spile length. The size of the Sp normally matches standardized rebar with diameters ranging from 25 to 50.8 mm. However, pipes with similar exterior diameters, as well as those up to the size of 101.6 mm have been used, for larger excavations. Illustrations of Spile design layout can be found within Sect. 6.1.

In low confinement stress conditions such as in Spile Grouted Umbrella Arches (SpGUA), it is easier to apply grout, through a perforated or non-perforated pipe, in order to lock in the Spile. However, in instances of high confinement, grout may not be required as it will be confined in place; such is the case with Spile Confined Umbrella Arches (SpCUA). In selected cases grout is not required as the pipe cavity closes during the drilling process. This was certainly the case at the Niagara tunnelling project (Niagara Falls, Canada) where 3–5 % of the Spile pipes drilled were not able to reach their required depth due to the high stress conditions (Gschnitzer and Goliash 2009). When the grain size is greater than gravel and ground improvement is required Sp (or Fp) can be used in

order to inject grout into the ground; this was denoted in Table 2 as the jet-grouting intervention under the field of application of terrain with boulders. An illustration of the various Spile applications with respect to grout can be found in Fig. 5a–c. These are: (a) SpGUA, grout only fills the annulus between the Spile and the ground material; (b) SpCUA, Spile is confined in its location due to the converging ground; and (c) SpGcUA, penetration of grout will connect to the neighboring penetrating grout.

Another consideration for the use of Spile support in order to construct the UA is the availability of equipment and length of the geological trouble region. Rockbolt installation equipment can easily be modified in order to install Sp, if Forepole installation equipment is not available. Furthermore, the size of the typical Forepole installation equipment are usually larger than equipment used to install rockbolts and could prove prohibitive in accessing shaft or side audits during a tunnel excavation. If a fault zone or small zone of weak structure is to be crossed by the tunnel alignment, it could be more economical to adapt the rockbolt equipment rather than to bring in

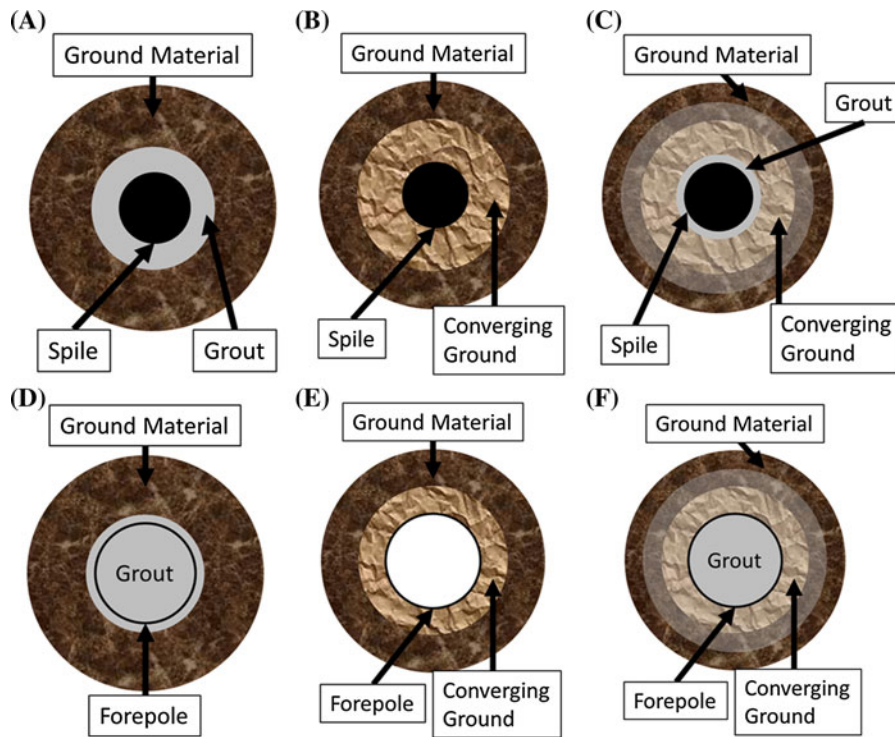

Fig. 5 Divisions of Spiles and Forepoles. **a–c** divisions of Spiles within the umbrella arch (cross-sectional view of support element). **a** SpGUA, grout only fills the annulus between the spile and the ground material; **b** SpCUA, spile is confined in its location due to the converging ground; **c** SpGcUA, penetration of grout will connect to the neighboring penetrating grout. Illustration shows a *solid bar* acting as the spile, however, pipes can also be used for this purpose. **d–f** divisions of Forepoles within the umbrella arch (cross-sectional view of support

element). **d** FpGUA (FpdGUA), grout only fills the annulus between the Forepole and the ground material, **e** FpCUA, Forepole is confined in its location due to the converging ground, **f** FpGoUA, penetration of grout will not connect to the neighboring grout Forepole for open applications. FpGcUA, (FpGdcUA) penetration of grout will connect to the neighboring penetrating grout Forepole continuous application. Illustration shows a pipe acting as the Forepole, however, *solid bars* can be used

Forepole equipment. It is important to note that is also possible to install Forepole elements with equipment used for Sp, if the Fp are installed in segments.

2.2.2 Forepoles

Forepoles are installed when a difficult and/or weak material is consistent for a large portion of the tunnel alignment and where there is a large potential for multiple geological structures of unfavourable orientation/structures to contribute to a possible failure. As previously mentioned, Fp have a larger diameter than Sp and their lengths are greater than the height of excavation. The stability of the face of the tunnel is derived by the fact that the Fp are long enough to embed themselves past the empirically derived Rankine active line, as shown in Fig. 6. This design length

is generally in agreement with Wang (2012), Fang et al. (2012), and Wittke et al. (2006). Another consideration for the length is that it exceeds the ensuing plastic region around and ahead of the face within these weak rock regions as illustrated in Vlachopoulos and Diederichs (2009). In addition, the angle of installation is shallow and typically between 3° and 8° from the horizontal in the longitudinal direction of the tunnel alignment. The typical theoretical drilling accuracy is ±2 % relative to the pipe length (Mager and Mocivnik 2000). The center to center spacing of the Fp is within the range of 30–60 cm, however, the spacing is defined by the requirement to create an individual arching effect in-between two sets of Fp (overlapping influence of support elements). The arching effect is also defined by the size of the Fp, which have an outside diameter

of 60–168.3 mm and a wall thickness of 5–10 mm. The overlap of the Fp range between 0 and 1/2 of the Forepole's length. The range usually depends on the use of additional pre-support methods that aid in the prevention of collapse of the face, such as face bolting. If the overlap of the successive Forepole UA's is greater than 1/2 of the Forepole length, it is referred to a double Forepole as there will always exist two layers of support between the tunnel wall and surrounding rock mass.

An illustration of the various Forepole applications with respect to grout can be found in Fig. 5d–f. (d) Fp can also be installed without grout, depending on the confinement (FpCUA—Fig. 5d). (e) However, if convergence must be controlled, the system can also be stiffened with the inclusion of grout (FpGUA—Fig. 5e). (f) If the system must be further stiffened or the inflow of water is an issue, grout can be employed to strengthen the material properties of the surrounding material (FpGoUA—FpGcUA—Fig. 5f). Depending on the risk, the stiffness or zone of permeability can be strengthened by ensuring that the grout penetration is being overlapped and/or employing the addition of a second layer of reinforcement (overlap $>L/2$) (FpdGUA—FpGcdUA).

2.2.3 Grouted

Grouting is commonly used in tunnelling projects as a preventive measure to control water seepage. It is also used to strengthen ground material, fill voids, secure bolts, rods (Sp or Fp), and, in the case of drilled holes, act as anchors (Warner 2004). This sub-category of UA support is referred to only when grout is used independently. Installation is similar to the installation required for Fp and Sp in terms of angle of installation

and overlap. Spacing, however, is defined by the allowable grouting pressure (which will ultimately define the radius of grout) as well as the requirement for the grouted zone to be connected (i.e. each grouted support element is installed separately but attached to each adjacent element, providing a continuous or uninterrupted arch structure) or open (i.e. each grouted support element is installed separately with spaces between the elements that create the arch structure). These types of grouted Umbrella Arches have been sub-categorized as grouted continuous Umbrella Arches (GcUA) and grouted open Umbrella Arches (GoUA) respectively. The length of a grouted UA depends on the availability of equipment but typically it is more economical to grout within the range of length of a Forepole (i.e. the length of the longitudinal support element that comprises the UA is greater than the height of excavation).

Since grout was first introduced in the 1800s as a means for reducing water leakage (decreasing permeability, κ) in bedrock underlying dams (Warner 2004), many types of grout have been developed for a variety of conditions as shown in Fig. 7. Furthermore, an understanding of the grout/material interaction has advanced significantly. The strength and/or reduction of a soil's expansiveness and the resulting reduction of swelling due to the mixture of calcium and clay soil, is one such advancement (Warner 2004). Grouting techniques can also increase the soil's cohesion strength and density (Warner 2004) minimizing subsidence. If this process is not properly monitored, it could lead to heave or breakthrough at the surface (Groutjacking). Furthermore, Grouting does not increase (in fact, in some cases it decreases) the frictional angle of the material (Shin et al. 2006). The selection of the grout method should be performed by

Fig. 6 Illustration of the Rankine failure line of a Double Forepole Confined Umbrella Arch (FpdGUA) (modified after Wang 2012)

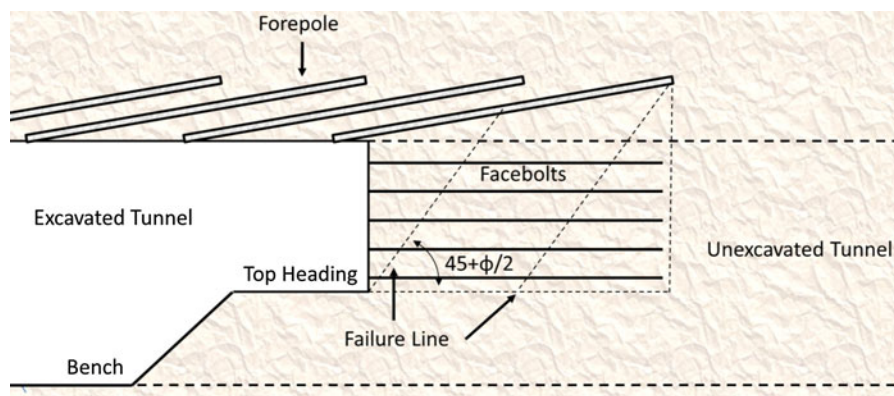

an experienced engineer because the selection grouting application still cannot be reduced further than the appropriate grain size type and stress conditions. Table 4 outlines examples of the various methods with respect to the jet-grouting (mixing) system only. Jet-grouting can increase the compressive strength of silt, sand, and gravel to a maximum of 5, 10, and 25 MPa respectively (Keller 2013). The authors have included herein examples of methods that have been published in literature in subsequent sections.

Despite its importance as a parameter, pumping rate information was not included within the summary of the data that was collected for this investigation. The

pumping rate influences the compaction or consolidation of the surrounding material. The higher the pumping rate, the faster the project can achieve completion. However, if compaction is to be used, special care must be given to high pumping rate in order to avoid soil fracturing.

3 Support Selection Methodology for an Umbrella Arch

Due to the aforementioned inconsistency of terms and their specific, relevant applications regarding UA

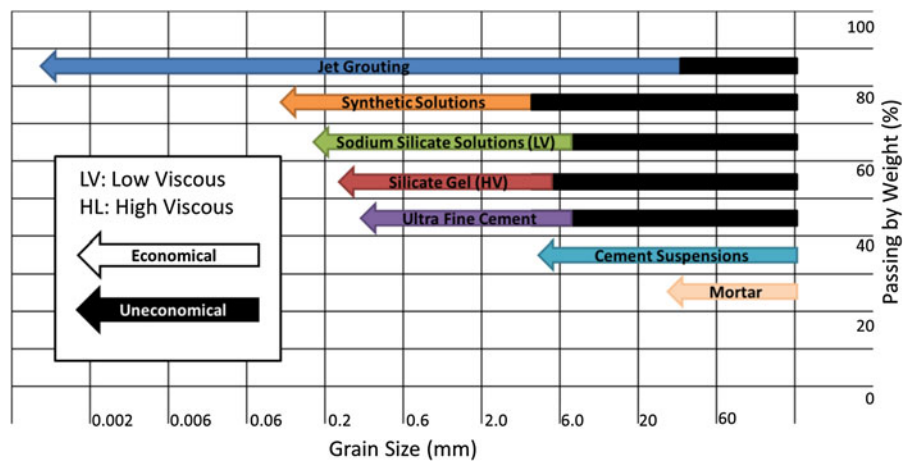

Fig. 7 Application limited for grouting techniques based on the work of (modified after Passlick and Doerndahi 2006)

Table 4 Typical injection parameters and respected column diameter for different jet-grouting systems (modified after Warner 2004)

Typical injection parameters	Jet grouting system			
	1-Fluid	2-Fluid		3-Fluid
		Standard	Jumbo/super jet	
Grout injection rate	38–113 L/min	68–132 L/min	567–660 L/min	68–132 L/min
Grout pressure	20–60 MPa	29–60 MPa	24.1–31 MPa	3.4–17 MPa
Air flow	–	3,679–5,943 L/min	11,320–14,150 L/min	2,679–5,943 L/min
Air pressure	–	0.6–1.2 MPa	0.8–1.4 MPa	0.6–1.2 MPa
Water flow	–	–	–	68–151 L/min
Water pressure	–	–	–	20–50 MPa
Rotation rate (RPM)	10–25	5–10	3–4	2–10
Withdrawal rate	10–50 cm/min	7–30 cm/min	7.6–10 cm/min	5–30 cm/min
Material/typical column diameter				
Cohesive soil	0.4–0.6 m	0.6–0.9 m	0.6–1.5 m	0.6–1.5 m
Granular soil	Max 1.2 m	Max 1.8 m	Max 3.6 m	Max 3.6 m

methods, the authors propose an UA selection methodology (Fig. 8). This UA selection methodology separates the design discrepancies as well as outlines the procedure for a specific UA technique based primarily on increasing quantity of fracturing, and confinement, control convergence, subsidence, and water presence. Figure 8 acts as an illustrative design aid for the UA (i.e. the decision to employ such a support methodology has been taken) in response to indications of difficult regions that require pre-support. The support selection methodology for an UA is present here in four distinct steps and is explained further in the sub-sections which follow.

3.1 Step 1: Type

The first step in the design process consists of an analysis and decision concerning whether pre-support is required for the unexcavated tunnel profile at the face. The selection of pre-support should depend on the personal experiences of the tunnel designer and

contractor. For example, Lunardi (2008), the creator of the analysis of controlled deformation in rocks and soils (ADECO-RS) method prefers the pre-support of core reinforcement with full face excavation over the UA type methods. In addition, exceptionally difficult terrain may call for the combination of multiple pre-support methods (i.e. an arrangement of shoring of the tunnel face, core reinforcement, and UA). It is outside the scope of this paper to state which method is most practical; however, if an UA is deemed appropriate, the designer can proceed to the second step of the selection chart.

3.2 Step 2: Mitigate Method

In the second step, the inclusion of a pre-support is based on the mitigation measures required to counter the expected behaviour of the ground due to tunnel excavation. It is important to note, that the information for this step should have been already been investigated prior to the selection of the excavation method

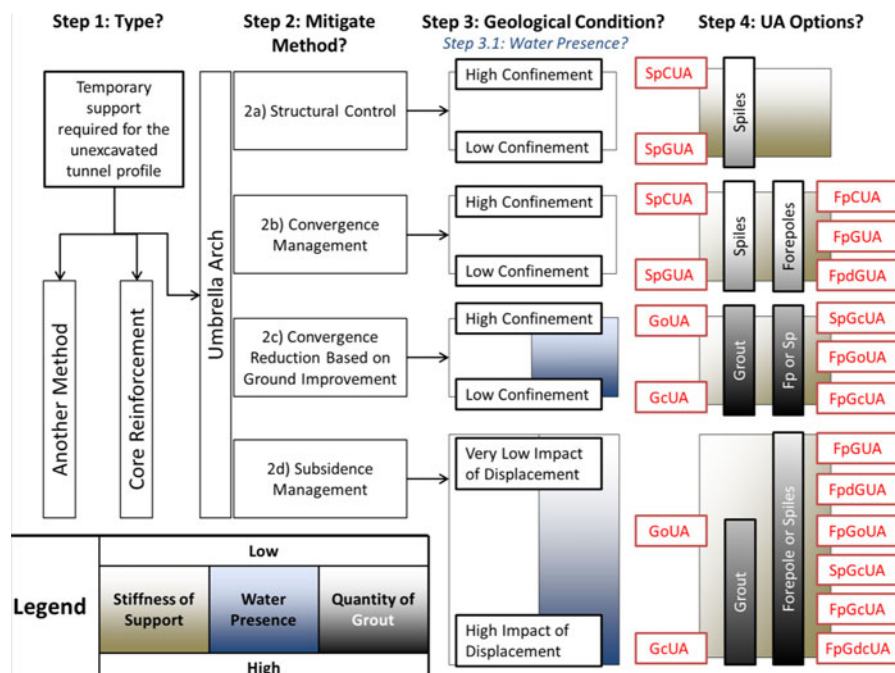

Fig. 8 Methodology for selection process of umbrella arch methods. *Step 1* Requirement for pre-confinement. *Step 2* Selection due to failure mode of ground material. *Step 3* ground conditions. *Step 3.1* water presence. *Step 4* selection process for stiffness and water presence. The methods increase with stiffness and protection from water as the selection process of *step 4* goes from the *top left* to the *bottom right*. *SpGUA* Spile Grouted Umbrella Arch, *SpCUA* Spile Confined Umbrella Arch,

SpGcUA spile Continuous Grouted Umbrella Arch, *FpCUA* Forepole confined umbrella arch, *FpGUA* Forepole Grouted Umbrella Arch, *FpdGUA* Double Forepole Grouted Umbrella Arch, *FpGoUA* Forepole Open Grouted Umbrella Arch, *FpGcUA* Forepole Continuous Grouted Umbrella Arch, *FpGdcUA* Forepole Double Continuous Grouted Umbrella Arch, *GoUA* Open Grouted Umbrella Arch, *GcUA* Continuous Grouted Umbrella Arch

(conventional or mechanical). Thus, the designer has to decide as to the pre-investigated ground behaviour type (Appendix 2) with the required mitigation method. The following four possible outcomes have been proposed based on increasing fracturing (i.e. ranging from wedge to raveling failure) and increasing convergence/subsidence management requirement (i.e. ranging from subsidence having no effect of an adjacent building to condemnation of the building):

- (a) *Structural control*: This response denotes a structural problem within the tunnel that must be controlled in order to achieve safe excavation. In other words, discontinuities generally govern the failure model of the tunnel (i.e. wedge to chimney). The decision to include an UA within the preliminary design would require some form of geological modelling and/or discontinuous analysis in order to aid in the definition of the anticipated structural failure. Furthermore, the support could also be installed solely as a safety precaution.
- (b) *Convergence management*: This mode is considered when undesirable convergence begins to occur due to the increase in gravity driven failures (i.e. chimney to raveling failure) and/or increase stress conditions (squeezing failure). If discontinuity failures or other forms of failure occur before the installation of the first support, an UA needs to be employed. If squeezing failure occurs (at depth), an UA needs to be employed to control the initial deformation, and to redistribute the stress conditions across other temporary supports.
- (c) *Convergence reduction based on ground improvement*: This outcome is similar to the previous one, with the exception that an analysis would find that the material parameters (permeability and/or cohesion) require improvement to make excavation possible. For example material grain size is too small, and could cause raveling in-between individual support elements of an UA (spile or Forepole). Another example is that the water presence requires a reduction of infiltration of water to prevent degradation of the tunnel face; and
- (d) *Subsidence management*: This outcome signifies that subsidence is a design factor and that

convergence must be controlled through the employment of a stiff UA.

3.3 Step 3: Geological Condition

The in situ stress confinement defines the geological condition for mitigation 2a–c. The type of confinement (high or low) will determine the temporary structural support, the amount of grout (i.e. the stiffness of the support) that will constitute the elements of the UA. For the final mitigation method (2d) the impact of tunnel subsidence will define the geological condition.

There are many different factors (i.e. infrastructure in the vicinity of the tunnel) which contribute to the limitations placed upon of tunnel subsidence. For example, the Aeschertunnel in Canton Zurich, Switzerland (Coulter and Martin 2006) had a subsidence limitation imposed associated with a sewer line. It can, however, be difficult to assign values of displacement on such a linear structure that might cause damage or failure of the sewer line; An analysis taking into account the Serviceability Limit State and Ultimate Limit State for tensile and compressive strain be conducted. The tensile strain associated with cast iron and lining concrete is 0.03 and 0.1 %, steel 0.5 and 0.1 %, ductile cast iron 0.1 and 0.2 %, and for plastic materials 0.7 and 2.0 % (Leca and Barry 2007). With regards to settlement of buildings due to tunnelling works, Aksoy and Onargan (2010) have summarized the work of other authors such as Attewell et al. (1986), in order to generate a range of maximum subsidence to an associated classification of possible building damage. Generally, if surface settlement is reduced to <10 mm there should be no structural damage.

3.3.1 Step 3.1: Water Presence

This step takes into account the influence of water with respect to subsidence caused by lowering the water table or deterioration of the tunnel face and the foundation zone of the UA. Leca and Barry (2007) state that the impact of lowering the ground water table varies in proportion to its magnitude and radius of influence: when localized, induced deformations are often prone to generating large differential settlements; when widely spread, the consequences are generally less severe. Therefore, the associated

support methods are measures which minimize the water inflow into the tunnel, if there is a high impact caused by the hydrology.

Dewatering techniques can be employed when water is present. In such cases, subsidence should not be an issue due to a drop in the water table. Dewatering techniques could be installed either from outside or inside the tunnel. This dewatering may be required as groundwater at the tunnel face may induce failures due to the hydraulic gradient worsening the mechanical conditions, the pre-existing mechanical instabilities, and the material properties (Leca and Barry 2007).

3.4 Step 4: Options: Choice of Umbrella Arch Sub-category

The fourth step is the selection of the appropriate UA sub-category. The substantiated decisions of the previous 3 steps leads the designer to the final choice of the UA sub-category that could be utilized for those predetermined conditions and relevant factors. As can be seen, more than one option can meet the requirements within the design chart. Closer analysis, however, may determine that a specific UA that has been initially selected might not provide adequate stiffness. To aid in the selection of the stiffer support, the layout of the UA options increase in stiffness from left to right and from top to bottom. If the issue of subsidence is a possibility, as previously stated, an analysis should be conducted in order to observe the effect of the supported tunnel at the ground level.

4 Cited Literature for Umbrella Arches

The determination of the standardized terminology as well as the development of the UA support selection methodology was predicated upon the findings of over 141 tunnel and cavern projects that have been published around the world. A summary of the results as determined through a rigorous Literature Review are documented in Table 3. The complete database of relevant information of all cited case studies can be accessed on-line. The authors can be contacted in order to provide interested parties with the salient particulars.

Nearly 50 years of UA applications make up the cited literature. Figure 9 illustrates the distribution of the literature review in terms of the date of the first

known publication and the type of UA support that was used. The various types of UA sub-category employed within the last half-decade illustrate the relevance and significance of this type of support within the tunnelling field. In addition to the applicability of such methods a significant trend that has been observed is that there is an increase in the use of UA references within the recent past. Such an increase suggests an increased interest in this application method, the suitability of such methods to be employed and the importance of standardizing the nomenclature and sub-categories of the UA. As an addition attestation, the Literature Review exposes numerous instances of published data which does not provide adequate enough information in order to classify the UA. The cases that do not provide adequate information are listed as Fp, G, and Sp (in which unsatisfactory or inconclusive information exists on grout or overlap) and are also listed as “?”, in which an UA was described but no technical design parameters were provided. The majority of the “?” cases are cited from publications which deal primarily with the geological conditions of a tunnelling project, as opposed to the tunnel construction and/or structure.

5 Umbrella Arch Selection Chart

The UASC was developed by the authors in an attempt to simplify the choice of UA based primarily on the use of relevant cited literature, previously mentioned. The chart can be seen in Fig. 10. The chart also serves to validate the methodology for the selection process of UA sub-categories (as per Sect. 3 and depicted in Fig. 8). The chart is firstly separated into the control measures required to mitigate the anticipated behaviour in terms of structural control, convergence management, convergence reduction and subsidence management. The compilation and determination of which UA type to use within each of these anticipated ground responses and/or limitations is summarized in each of the subsections below.

5.1 Structural Control

In an effort to aid in steps that are involved in the support selection methodology for an UA (i.e. Steps 2 and 3 as defined in the previous section) the incorporation of the tunnel behaviour chart (TBC) by Marinov

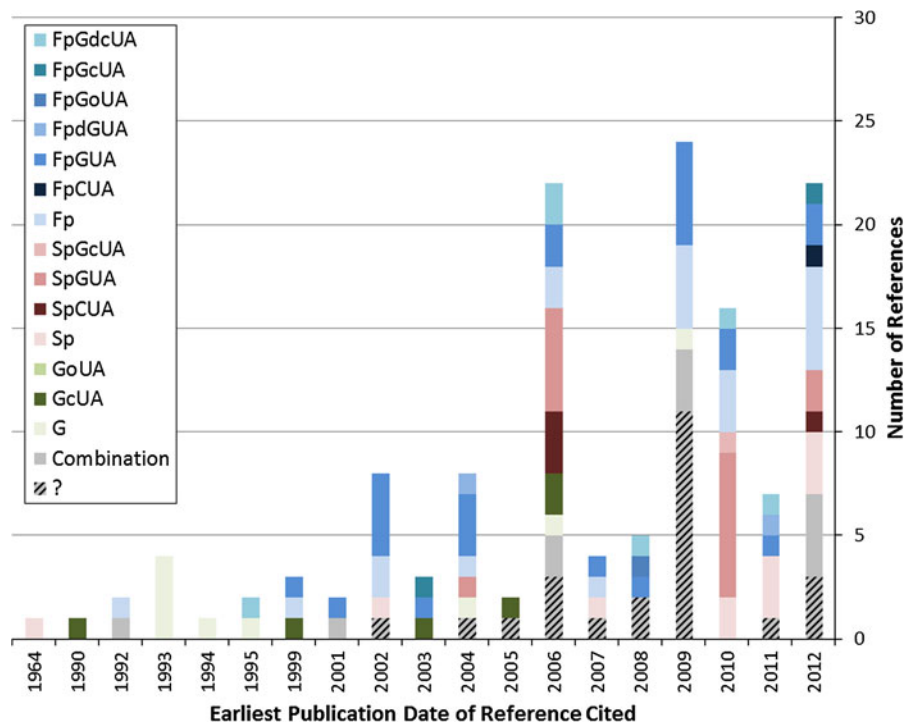

Fig. 9 The distribution of the earliest referenced publication date cited for umbrella arches. *SpGUA* Spile Grouted Umbrella Arch, *SpCUA* Spile Confined Umbrella Arch, *SpGcUA* spile Continuous Grouted Umbrella Arch, *FpCUA* forepole confined umbrella arch, *FpGUA* Forepole Grouted Umbrella Arch, *FpdGUA* Double Forepole Grouted Umbrella Arch, *FpGoUA* Forepole Open Grouted Umbrella Arch, *FpGcUA* Forepole Continuous Grouted Umbrella Arch, *FpGdcUA* Forepole

Double Continuous Grouted Umbrella Arch, *GoUA* Open Grouted Umbrella Arch. Inconclusive information involving a spile element (Sp). Inconclusive information involving a forepole element (Fp). Inconclusive information involving a grout element (G). Combination of forepole, Spiles, and grout, resulting in a different classification (combination). Inconclusive information involving an umbrella arch (?)

(2013) can be utilized for the structural control (Appendix 2). The TBC allows the designer to predict the failure case, which is also associated with overburden (confinement of the ground material). The authors have practically paired up tunnel behaviour cited in case studies cited in literature with the TBC equivalents in order to validate the design chart for the structural control section.

5.2 Convergence Management

Similarly, the TBC was also employed to quantify the selection of an UA under the mitigation method of convergence management. However, the TBC solely would not able to differentiate the differences between UA elements, Fp and Sp. That selection process would still be up to the tunnel design engineers' judgement.

5.3 Convergence Reduction Based on Ground Improvement

The TBC could not completely simplify the convergence reduction mitigation method as due to its limitations. One limitation is that the TBC only takes into consideration materials that are able to be processed by GSI, as opposed to soil. A second limitation is that the TBC does not further classify the effect of ground water. The TBC does note that the presence of water does not generally change the failure mode, but does affect the factor of safety. The only failure mode that water has a large effect on is chimney, and ravelling (only from blocky-disturbed and disintegrated) which would result in a flowing ground failure mode.

The convergence reduction based on ground improvement section could be simplified through the

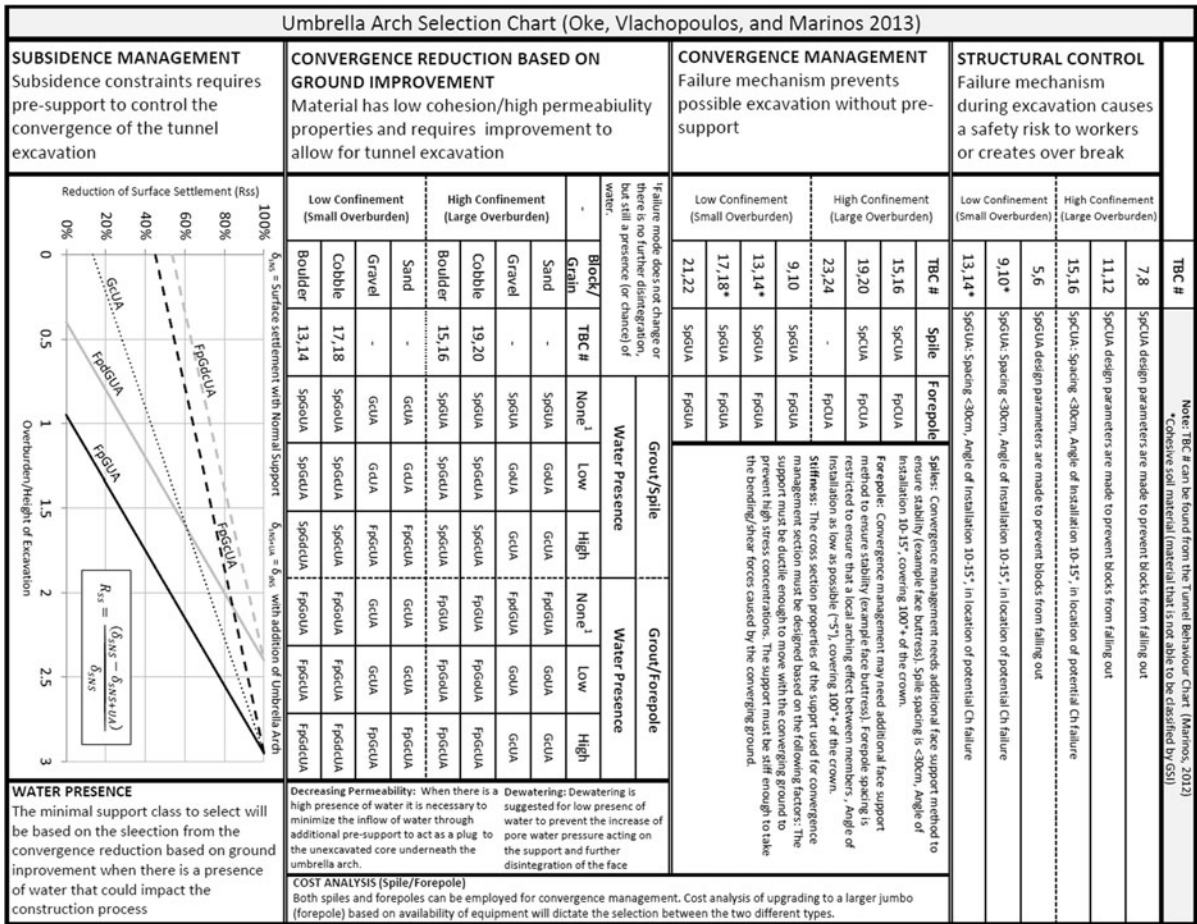

Fig. 10 Umbrella Arch Selection Chart. SpGUA Spile Grouted Umbrella Arch, SpCUA Spile Confined Umbrella Arch, SpGcUA Spile Continuous Grouted Umbrella Arch, FpCUA forepole confined umbrella arch, FpGUA Forepole Grouted Umbrella Arch, FpdGUA Double Forepole Grouted Umbrella

Arch, FpGoUA Forepole Open Grouted Umbrella Arch, FpGcUA Forepole Continuous Grouted Umbrella Arch, FpGdUA Forepole Double Continuous Grouted Umbrella Arch, GoUA Open Grouted Umbrella Arch, GcUA Continuous Grouted Umbrella Arch

addition of the grain sizes into the selection chart. For example, it is suggested by John and Mattle (2002) if sand or gravel lenses are to be expected, two rows of tubes shall be provided. But if the excavation material is completely cohesionless, then grouting is required. With reference back to Fig. 7, most methods of grouting materials/methods within the figure cannot be installed within grain sizes larger than cobble. The two grout materials listed that were successfully installed within cobble are most commonly installed through an injection method. Injection method can easily be incorporated with Spile or Forepole supports elements through the incorporation of injection ports. Such division of grain size have been incorporated in the UASC, and verified by selected published

literature. Further simplification of convergence reduction based on ground improvement section was not quantified in order to avoid standardization of inexperienced engineers as the authors deem that selection remains a case by case process.

5.4 Subsidence Management

The Subsidence Management section was based on the literature review gathered (as previously mentioned) of a variety of tunnelling projects and numerical analysis results (Fig. 11; Table 5). The tunnelling projects had either conducted numerical analysis or observed the reduction of surface settlements due to the employment of an UA (Table 5). Characteristic

curves were plotted based on the data from the literature review shown in Table 5, along with numerical trends found from the works of Kimura et al. (2005) (Fig. 12). The first set of characteristic curves found the upper and lower bounds of data collected from literature to find possible reduction of surface settlement due to the use of FpGUA. The lower bound of the FpGUA data captures the conservative possible reduction of surface settlement due to the employment of a FpGUA. The upper bound of the FpGUA data captures the conservative possible reduction of surface settlement due to the employment of a FpdGUA.

To create the other characteristic curves, the authors used the relationship found from Kimura et al. (2005) for GcUA and FpGcUA based on the lower bound trend of FpGUA. Kimura et al. (2005) found the reduction of surface settlement from increasing the stiffness of the UA. The observed and numerical results, found that there can be a reduction of surface settlement between 27 and 37 % if one switches from FpGUA to FpGcUA. Furthermore, the authors also used the another relationship found by Kimura et al. (2005) to create FpGcdUA characteristic curve based on the upper bound of FpGUA (lower bound of FpdGUA). Kimura et al. (2005) found as an

increase of reduction of 40 % if one switches from GcUA to FpGcUA.

Only one of the five data points (GcUA) falls outside the resulting characteristic curves. This point is a GcUA, found from comparing the lowest amount of settlement captured by numerical analysis of the Bonn-Bad Godesberg Tunnel (Wittke et al. 2006). No explanation was given for this anomaly of small surface settlement. However, the observed and largest numerical results of surface settlement still fall within the GcUA and the FpGcUA characteristic curves.

The UASC will further assist designers in the selection process of an appropriate initial design for an UA. The method in which to use the UASC as a design tool is to proceed down the four categories of the UASC (structural control, convergence management, convergence reduction and subsidence management) upgrading the support class as required (never down grading). For example, following the convergence management design path may yield one to select a FpCUA based on a TBC of 20 (Appendix 2), but due to the existing presence of water, this can cause the support to change to a FpGoUA or FpGcUA or FpGcdUA based on the requirement of a reduce infiltration of ground water. In another example, hydrology and/or grain size

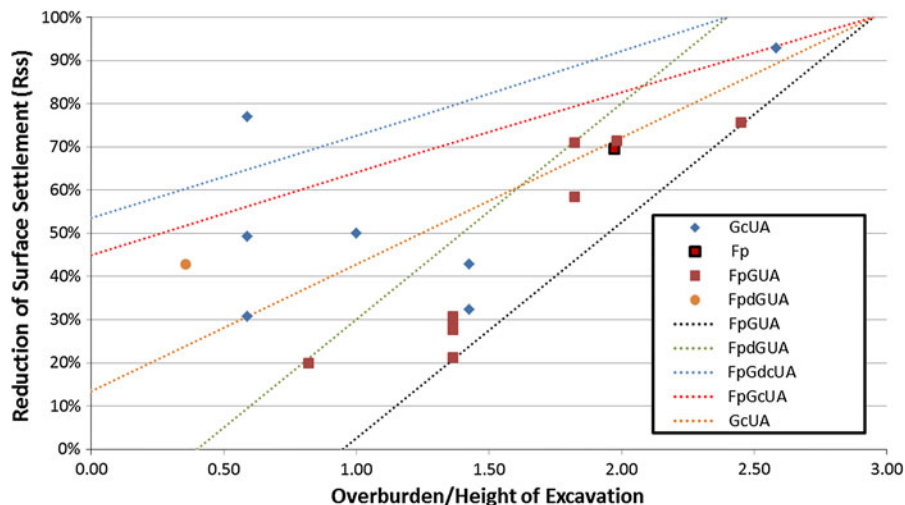

Fig. 11 Literature review data of tunnelling projects that have had analysis conducted or observed the reduction of the surface settlement based on the usage of an umbrella arch. *Trend lines* indicate the potential reduction of surface settlement due to the employment of an umbrella arch system (above the associated

line). *FpGUA* Forepole Grouted Umbrella Arch, *FpdGUA* Double Forepole Grouted Umbrella Arch, *FpGcUA* Forepole Continuous Grouted Umbrella Arch, *FpGdcUA* Forepole Double Continuous Grouted Umbrella Arch, *GcUA* Continuous Grouted Umbrella Arch

Table 5 Literature review of tunnelling projects that have had analysis conducted or observed the reduction of the surface settlement based on the usage of an Umbrella Arch

Tunnel	Reference	UA method used	Overburden/ height of excavation	Settlement without UA (mm)	Settlement with UA (mm)	Reduction of surface settlement (%)
Aeschertunnel	Coulter and Martin (2006)	GcUA	2.58	350 ^a	25 ^a	93
Underground station "Taborstraße"	Pichler et al. (2003)	GcUA	1.00	90 ^b	45 ^b	50
Bonn-Bad Godesberg Tunnel	Wittke et al. (2006)	GcUA	0.59	65 ^a	15 ^a	77
Bonn-Bad Godesberg Tunnel	Wittke et al. (2006)	GcUA	0.59	65 ^a	45 ^a	31
Bonn-Bad Godesberg Tunnel	Wittke et al. (2006)	GcUA	0.59	65 ^a	33 ^b	49
Taksim to Yenikapi (Istanbul metro line)	Yasitli (2012)	FpGUA	1.82	109.7 ^a	45.6 ^a	58
Taksim to Yenikapi (Istanbul metro line)	Yasitli (2012)	FpGUA	1.82	138 ^b	40 ^b	71
Fort Canning tunnel	Yeo et al. (2009)	FpGUA	0.82	100 ^a	80 ^a	20
Istanbul Metro (Zone F to Zone C) between Unkapani and Yenikapi	Ocak (2008)	FpGUA	1.98	140 ^a	40 ^a	71
Istanbul Metro (Zone G to Zone A) between Unkapani and Yenikapi	Ocak (2008)	FpGUA	2.45	370 ^a	90 ^a	76
Based on Trojane Tunnel (30 pieces)	Volkman and Schubert (2006)	FpGUA	1.36	250 ^a	175 ^a	30
Based on Trojane Tunnel (20 pieces)	Volkman and Schubert (2006)	FpGUA	1.36	250 ^a	181 ^a	28
Based on Trojane Tunnel (10 pieces)	Volkman and Schubert (2006)	FpGUA	1.36	250 ^a	197 ^a	21
Based on Trojane Tunnel (20 pieces +)	Volkman and Schubert (2006)	FpGUA	1.36	250 ^a	173 ^a	31
Dulles Corridor Metrorail Project	Gall et al. (2011)	FpdGUA	0.36	35 ^b	20 ^b	43
Izmir Metro	Aksoy and Onargan (2010)	Fp	1.97	23 ^a	7 ^b	70

^a Numerical data^b Observed data

conditions could result in determining that a GcUA be employed based on convergence reduction mitigation method. However, an additional design requirement of controlling subsidence (i.e. subsidence management) could result in the employment of an FpdGUA in order to ensure the reduction of surface settlement of 30 %, if overburden to height of excavation ratio of 1. GcUA would govern the design as it will meet both requirements: ground improvement; and surface settlement reduction of great than 30 % (44 %).

6 Employment of Umbrella Arch Methods

The following subsections define each of the individual sub-categories of the UA. For the majority of the individual sub-categories, a tunnel example is referenced in order to illustrate the practicality and employability of the proposed support selection process. The Case Studies that have been cited and that are used for illustration purposes are summarized in Table 6. Furthermore, in order to illustrate (and validate) the UA support selection process, each case

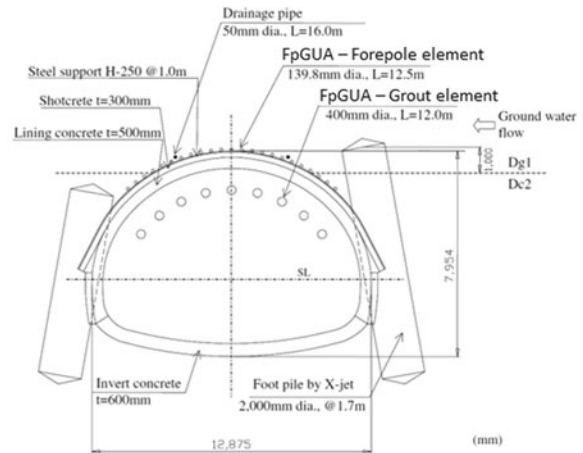
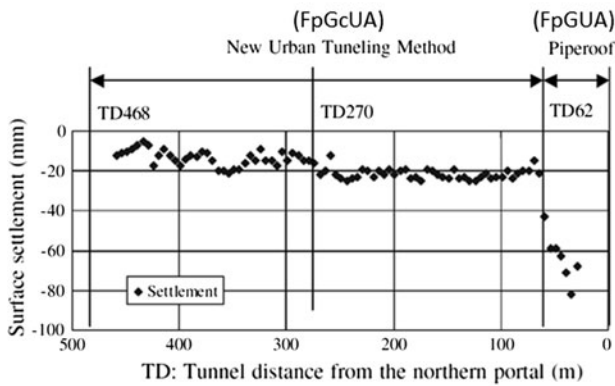

Fig. 12 *Left* observed longitudinal surface settlement for the Baikoh tunnel excavation (modified after Kimura et al. 2005). *Right* new urban tunnelling method (NUTM) (modified after Kimura et al. 2005). The difference between the NUTM design and piperroof is the addition of the horizontal jet grouting

underneath the long steel pipe forepiling and the jet-grouting side foundations. Piperroof would be classified as a FpGUA, and the NUTM would classify as a FpGcUA, due to the possible interaction of the jet-grouting installed just below the crown

study presented also includes the process and assessment (through the use of the UASC).

6.1 Employment of Spiles

6.1.1 Buon Kuop Hydropower Project

According to Trinh et al. (2007), one of the tunnels of the Buon Kuop hydropower project, in Vietnam, hit a zone of weakness that was 15–20 m long during a twin tunnel drill and blast excavation. The result of excavating in this weakness zone was a cave-into the surface (60 m above the excavation), which, in turn, created a sink hole. Utilizing the information provided by Trinh et al. (2007) and applying it to the UASC, this would result in a preliminary design selection of a SpGUA. The selection of the SpGUA would be based on a requirement for convergence management as the weakness zone encountered (15–20 m long) prevented further excavation with some sort of pre-support. The available equipment only allowed for the installation of rods that measured 6 m in length, therefore it was not economical to use other methods associated with support elements of a longer length (i.e. Fp) for such a short section of the overall tunnel alignment. SpGUA would have been selected based on the TBC #13 due to the block structure (GSI value range of 20–30 with

Table 6 Summary of published employment of Umbrella Arch methods

Tunnel	Publication	UASC selection
Buon Kuop Hydropower Project	Trinh et al. (2007)	SpCUA
Platanos Tunnel	Marinos and Tsiambaos (2010)	SpGUA
Kukuan Tailrace Hydropower Plant Tunnel	Liu et al. (2010)	SpGcUA
Platamon(as) Pilot Tunnel	Marinos and Tsiambaos (2010)	FpGUA
Tunnel San Fedele (Roveredo bypass project)	Fasani et al. (2012)	FpGoUA
Maiko Tunnel	Harazaki et al. (1998)	FpGcUA
Driskos Tunnel (Egnatia Odos)	Vlachopoulos et al. (2013)	FpCUA
Golovec Tunnel	Bizjak and Petkovsek (2004)	FpdGUA & SpGUA
Seoul Subway Line 9 (construction site 912)	Kim (2008)	FpGdcUA
Malakasi C Twin Tunnel	No published data, authors personal notes	GoUA
Aeschertunnel	Coulter and Martin (2006)	GcUA

Fair to Poor joint conditions), overburden <70 m (60 m), and with a σ_{ci} value of <15 MPa (10.84 MPa).

However, further investigation would show that this zone of weakness occurred in a valley of two mountain ranges (Fig. 13a), resulting in higher stress conditions than were indicated by the pure overburden. The higher stress conditions would eliminate the grout requirement, which would result in SpCUA as the final selection of the UA to traverse the weakness zone.

The SpCUA used at the Buon Kuop hydropower project consisted of the following: 6 m long Sp which were installed around the crown of the 9 m high excavation; 50 mm in diameter support which were spaced at 35 cm and installed at an angle 16° from the tunnel axis, and, as previously mentioned, confined in their location. An illustration of the design for the cave-in tunnel and the second tunnel design as it encountered the weakness zone are presented in Fig. 13b, c, respectively. More information on the Buon Kuop hydropower project in Vietnam is described in Trinh et al. (2007).

6.1.2 Platanos Tunnel

The Platanos tunnel project, in Greece, is consisted of 15 different combinations of support classes within varying geological conditions. All 15 designs incorporate UA type supports, with nine of the 15 combinations using Sp. Six (6) of the nine Spile designs were based on structural type failure (at low overburden) where the ground conditions contain few

indications of loose to slightly cemented coarse grain material (conglomerate). This local failure could, potentially cause failures similar to TBC #9, 10, 13, and 14; these results in a SpGUA installed locally in regions with such conditions. A layout of the general support with Forepole of the Platanos Tunnel can be found within Figs. 14 and 15.

There were three different types of SpGUA used at the Platanos 11 m high excavation. The three different SpGUA varied by different stiffness's associated with the tunnel overburden and/or weaker materials encountered. The different Sp had diameters ranging from 28 to 32 mm rods (with a maximum overburden of 50 m), and 51 mm (5 mm thickness) pipes (with a maximum overburden of 100 m). All Sp had a length of 6 m with a center to center spacing ranging from 25 to 35 cm. For further information about this Platanos tunnel and the other structural supports used during construction please refer to the following design documents (as summarized in Marinos and Tsiambaos (2010)).

6.1.3 Kukuan Tailrace Hydropower Plant Tunnel

The UA that was selected for the preliminary design of the Kukuan tailrace hydropower plant tunnel, in Taiwan, was based on the information provided within Liu et al. (2010). The ground material was described as highly fractured sandstone and slate that was saturated. As such, it was necessary to create a grout sealing around the 7.6 m high tunnel excavation as the tunnel was being constructed underneath a river in material with permeability of $13\text{--}17 \times 10^{-5}$ cm/s.

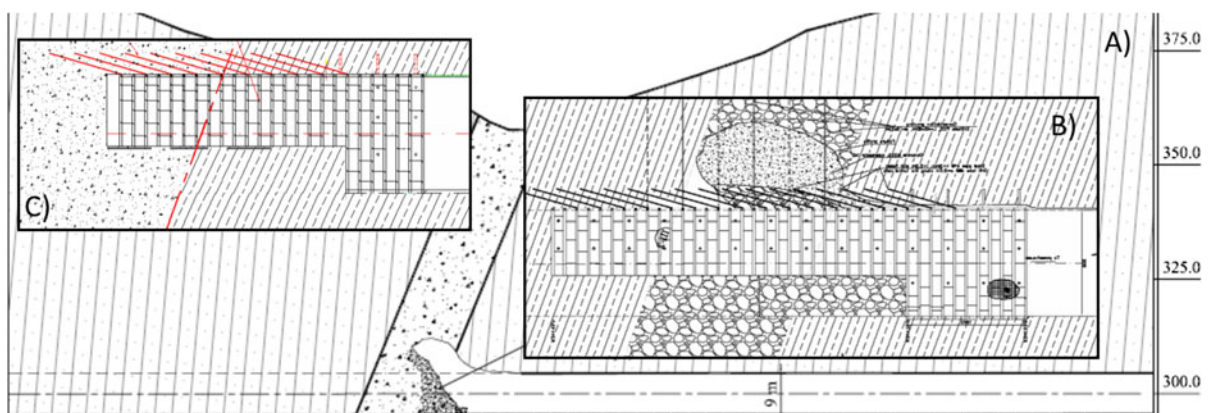

Fig. 13 a Cave-in at the first headrace tunnel (modified from PMU5, 2005), b Excavation in the first tunnel of Buon Kuop hydropower project. c Excavation in the second tunnel—longitudinal sections of Buon Kuop hydropower (Trinh 2006)

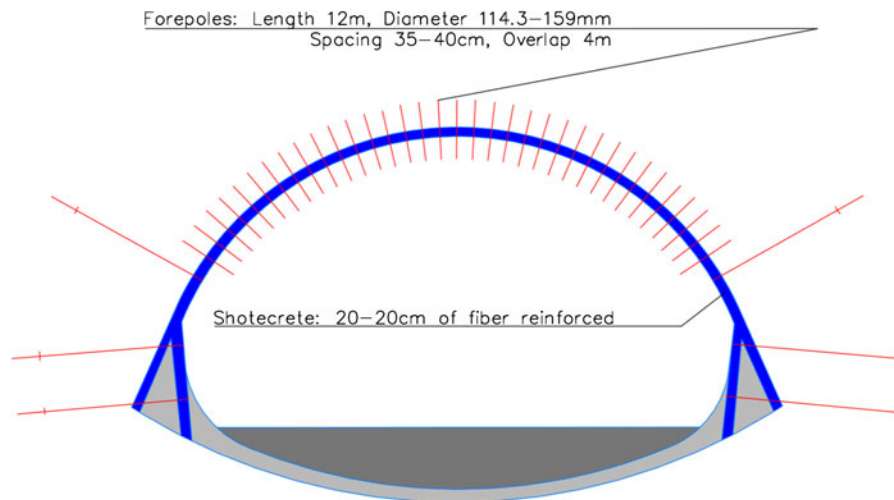

Fig. 14 General structural design of the Platanos tunnel with Forepoles (modified after Marinos and Tsiambaos 2010)



Fig. 15 Platanos tunnel section during a site visit by the authors in December 2010

This high influence of the hydrology and highly fractured material (TBC #15) required the mitigation of convergence reduction based on ground improvement. Selection of the UA was further restricted due to the requirement of a 7 m diameter access shaft. This restriction combined with the geological conditions would result in a SpGcUA following the procedure of the UASC.

The SpGcUA selected had a length of 6 m, spaced every 2 m. The Spile elements were 50 mm in diameter. The Spile element was very successful in increasing the stiffness of the system and providing a means of injection of grout into the fractures of the

rock cover measuring 3.5 m, with 40 + m of overlying alluvium debris deposited from a recent earthquake. It was noted by Liu et al. (2010), that longer grouting column elements take less of a time commitment during the shaft excavation sequence, as the contractors increased the grouting from 2–3 to 6 m (i.e. varying length of grout element) during the shaft construction. However, as previously stated, the restrictions of the access shaft prevented further increases of grouting length. The orientation and placement of the Spile elements can be seen in Fig. 16. More information on the project can be found within Liu et al. (2010).

6.2 Employment of Forepoles

6.2.1 Platamon(as) Pilot Tunnel

The Platamon(as) tunnel is a twin highway tunnel connecting Athens with Thessaloniki, Greece. During excavation the north bound traffic tube had a 40 m long collapse at the tunnel face, this propagated to the south bound tunnel causing a 20 m long collapse at its face. To proceed through the failed region, a pilot tunnel was required. During a site visit, in December 2012, the authors were able to inspect the geological conditions and found that a FpGUA would have been selected as a preliminary design based off of the UASC. The preliminary report for the project indicated that the material at the problematic section would be a disintegrated serpentinized peridotite/scree material with a GSI of 5–15 with 10 m of overburden (TBC #17). The north bound tunnel was being over excavated during a site investigation conducted by the authors. This opportunity allowed for an assessment of the material. The material was classified as a highly serpentinized preidotites, tectonically sheared to clay-like material with hard clasts up to 3 cm diameter (Fig. 17). The overburden of the tunnel was approximately 17 m (TBC #21). Furthermore, Fp were easily employed as the machinery used to install them was already on site.

The support class employed at the failed sections was support 7A, using a FpCUA. The FpCUA employed was 12 m long, 114 mm in diameter, with 4 m of overlap. The support was installed covering

100° of the crown, of the almost 12 m high excavation. For further information on the support classes and other design parameters can be found in Marinou and Tsiambaos (2010).

It is important to note that the over excavation employed an UA type technique as shown in Fig. 17. However, these supports were not installed during the first past, which falls outside the authors' description and the UA.

6.2.2 Tunnel San Fedele (Roveredo Bypass Project)

The material encountered at the southern section of the Roveredo bypass project, in Switzerland, consisted of slightly silty gravels with abundant to predominant sand, stones, and blocks with a maximum of 25 m of overburden. (Fasani et al. 2012). The material has no genuine cohesion and is only slightly interlocked. The UASC would place the requirement for pre-support as a convergence reduction based on ground improvement. The impact of water low, as the water table was below the excavation and the impact at surface can be omitted based on the land is primarily farmland. The presence of stones and blocks would push the selection to a FpGoUA support type (with drainage) as grouting techniques such as jet-grouting are not ideal in materials with such large grain sizes.

The actual selection of the temporary tunnel support was a FpCUA (no reference to grout used within support description) that was 15 m long, on the ~6 m high top heading excavation, with 5 m of

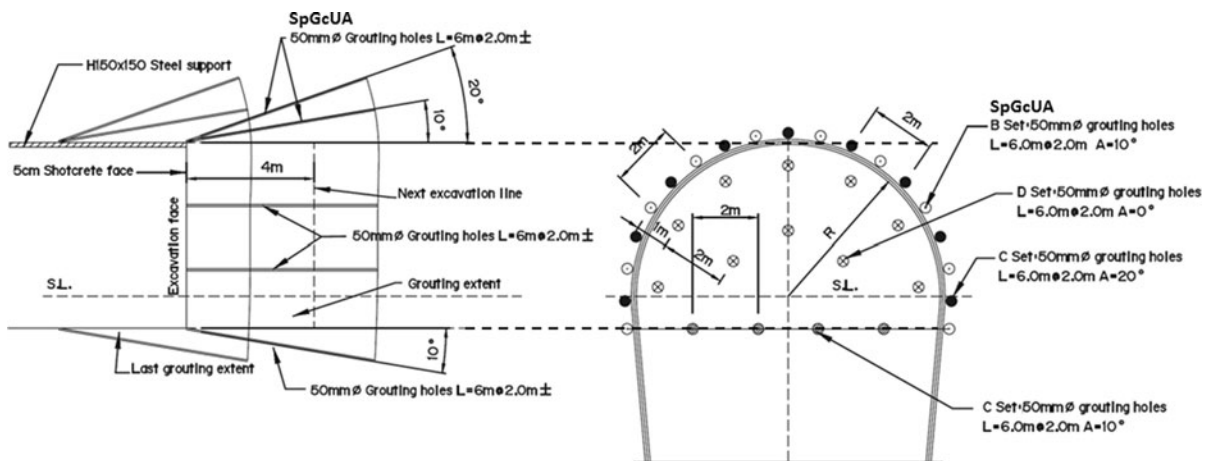

Fig. 16 Cross sections of the SpGcUA Kukan Tailrace hydropower plants tunnel (modified after Liu et al. 2010)

overlap (Fig. 18). The Fp were spaced at 50 cm (20 pipes on during excavation of the top heading) in combination with 12 m long face anchors to ensure stability of the face. A loose section was encountered at the south portal and was persistent for approximately 150 m. However, the spacing allowed for grain sizes smaller than 40 cm to pass through the Fp. The material lost was backfilled with concrete, however, at a selected location there was a propagation of a chimney type failure to the surface (Fig. 19). This failure lead to reduction of the Forepole element spacing from 50 to 40 cm, and the application of grouting in the loose ground sections. Further details

associated with the San Fedele Tunnel can be found in Fasani et al. (2012).

6.2.3 Maiko Tunnel

According to Harazaki et al. (1998), the Maiko Tunnel in Kobe, Japan, is a 3.3 km twin highway that has an excavation width of 16 m and height of 11–12 m. Two geological conditions were encountered: (1) Alluvial zone (uncemented sand and gravel in alluvium and embankments); and (2) diluvial zone (uncemented gravel and clay). The ground water was found to be near ground surface

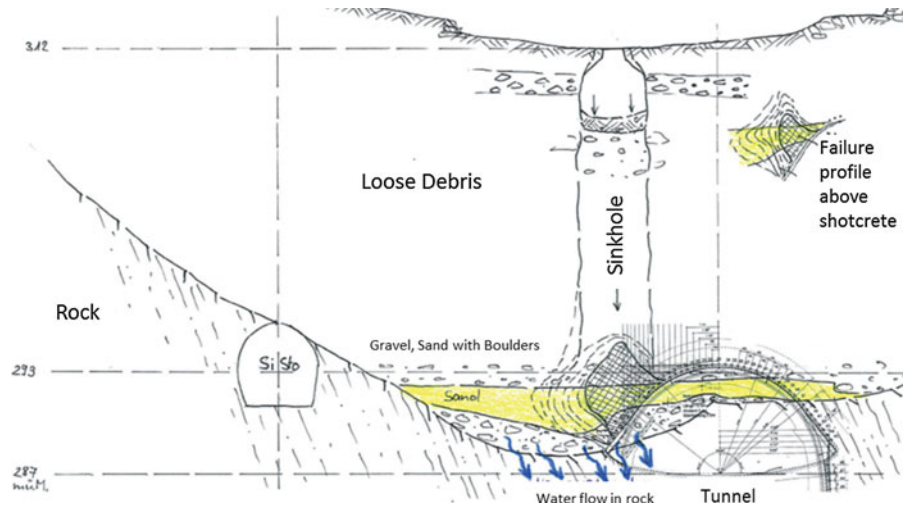

Fig. 17 Over excavation of the pilot tunnel in the south bound tunnel, December 2012



Fig. 18 Tunnel San Fedele (Roveredo bypass project) south portal during a site visit by the authors in 2011

Fig. 19 Earth fall on 4 June 2010, cross-section at about Tm 48 of Tunnel San Fedele, (modified after Fasani et al. 2012)



for both zones. The tunnel passes 4–7 m under an athletic ground of a school and close to existing school buildings (closest building is 10 m from the excavation). Pre-support was required, as construction from surface was not possible and given the instability of the uncemented material (gravel and sand). According to the UASC, a FpGcUA would have been selected for both sections as convergence reduction based on ground improvement because of the presence of gravel/sand, low overburden, and high presence of water. Surface subsidence was a consideration due to the close proximity of the school buildings. Due to the fact that the existing surface infrastructure is approximately an excavation height distance away from the centreline of the tunnel, combined by the fact that the UA support selected is the second stiffest type of UA, the effect on the surface settlement at the surface will be minimal to insignificant if design correctly. No damage to the school building infrastructure was recorded in the publication of Harazaki et al. (1998).

Harazaki et al. (1998) describes the pre-support system used as an umbrella method (umbrella fore-pile) which consisted of long steel pipes and consolidation grouting (FpGcUA). The pipes had a length of 12 m, diameter of 114.3 mm and a thickness of 6 mm. The maximum surface settlement was found to be 100–120 and 20 mm for the alluvial and diluvial zone respectively. Due to the large surface settlement in the alluvial zone, the standard cement mortar was replaced with ultrafine cement mortar; improved

support performance metrics were not provided based on this change. More information can be found within Harazaki et al. (1998).

6.2.4 Driskos Tunnel (Egnatia Odos)

The design of weakest section (very thin bedded sandstones and thin bedded siltstones, Sect. 4 of cited reference) of the Driskos Tunnel, in Greece, required an UA (Fig. 20) to be able to excavate through the fractured flysch material (Vlachopoulos et al. 2013). The Umbrella Selection Chart would have selected a FpCUA (over 650 m length of the overall tunnel length) to provide convergence management. The blocky to disintegrated material, with a σ_{ci} of 26–75 MPa, with overburden range of 100–220 m would yield a TBC #16 or 20.

However, FpGUA was selected by the designer with the following specifications as shown in Fig. 21 for the 9.47 m high, horse-shoe tunnel excavation. The Fp were 12 m long, 101 mm in diameter with 4 m of overlap, and installed at an angle of 5.78° off of the tunnel axis. For further information on the Driskos tunnel, please refer to Vlachopoulos et al. (2013) and Vlachopoulos (2009).

6.2.5 Golovec Tunnel

The Golovec Tunnel was constructed as part of the city of Ljubljana's ring road in Slovenia. The 10.5 m high tunnel excavation was constructed with a low overburden (<80 m) with the added constraint of crossing

under two roads. An UA was employed in order to allow for excavation and also to reduce subsidence that could potentially disrupt traffic flow on the road above and minimize the risk of landslide. According to Bizjak and Petkovsek (2004), a landslide occurred during the first excavation of the tunnel portals. Once the tunnel was excavated past the portal, landslide region it encountered a zone of highly weathered quartz sandstone, with a GSI range of 10–15. The geological conditions would indicate a TBC #18.

Based on the requirement for convergence management, a FpGUA would be selected using the UASC. However, due to the presence of roads above the tunnel excavation and the landslide potential, the selection would fall into the Subsidence Management section (resulting in the requirement of a numerical analysis). A FpdGUA was found to control the subsidence of the 10.5 m high tunnel excavation during the worst of the geological conditions, however, the SpGUA was able to provide enough



Fig. 20 “Saw-tooth” profile of the umbrella arch installed in the Driskos tunnel

Fig. 21 Longitudinal cross-section of Driskos showing tunnel support (class V) detail (modified after Vlachopoulos et al. 2013)

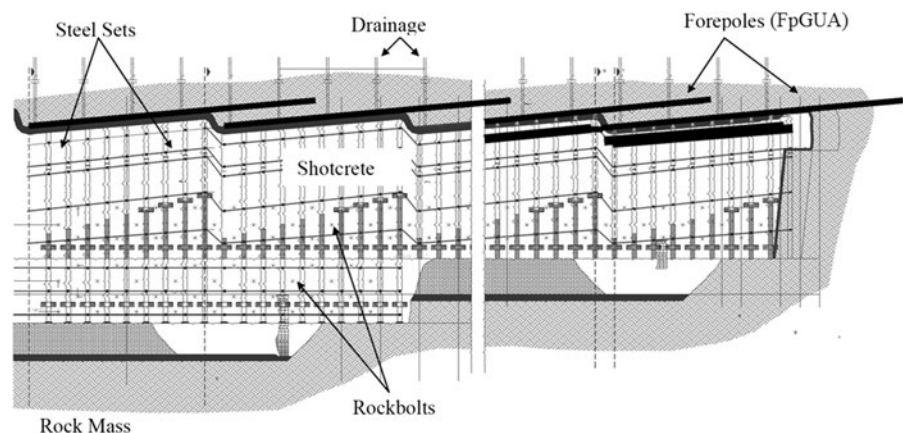

protection in more stable conditions (Bizjak and Petkovsek 2004). The general layout of the tunnel support case can be seen in Fig. 22.

The FpdGUA had an overlap of 6–9 m of the 12–15 m long Fp. The SpGUA had overlap of 3 m of the 9 m long Sp. The Forepole/Sp used was a 4 (101.6 mm) iron pipes filled with mortar that were spaced 30 cm apart (center to center). For more information of the supports used on the project please refer to Bizjak and Petkovsek (2004).

6.2.6 Seoul Subway Line 9 (Construction Site 912)

According to Kim (2008), the Seoul subway line 9 at construction site 912 was constructed in an alluvial deposit near the Han River. The 8.5 m high tunnel section was constructed with only 18 m of overburden and with the water Table 1.5 m below surface. The 14-storey apartment buildings and five-story shopping centers were also in close proximity to the construction site. Should the information provided by Kim (2008), be applied to the UASC, it would result in a preliminary design for a pre-support of minimum stiffness of GcUA. The GcUA is the minimum support that will meet the requirement for both mitigation methods of ground improvement based on ground improvement (due to the water present) and subsidence management (impact of the infrastructure above

the tunnel). A FpGdcUA was successfully employed with further dewatering techniques (Fig. 23) (Kim 2008).

The Forepole elements used as part of the FpGdcUA were 114 mm diameter pipes, 13.5 m long, with a center to center spacing of 60 cm. The grouting process was classified as jet-grouting, with the whole system overlapping 7.1 m with the grouting length 13.4 m. This resulted in a minimum of 2 layers of reinforcement through the region underneath the apartment buildings. For more information regarding the Seoul Subway Line 9 at construction site 912 please refer to Kim (2008).

6.3 Employment of Grout

6.3.1 Aeschertunnel

The Aeschertunnel, in Switzerland, was constructed in a glacial moraine which consisted of a brown clayey sand and silt, with gravel and isolated boulders (cohesion strength was 5–20 kPa). During excavation, the unsupported vertical face showed no signs of instability. A critical section of the tunnel alignment was defined that consisted of overhead roadways, a sewer line, a concrete stream diversion channel, and a nearby house. These infrastructures could potentially be affected by the subsidence of the tunnel with only

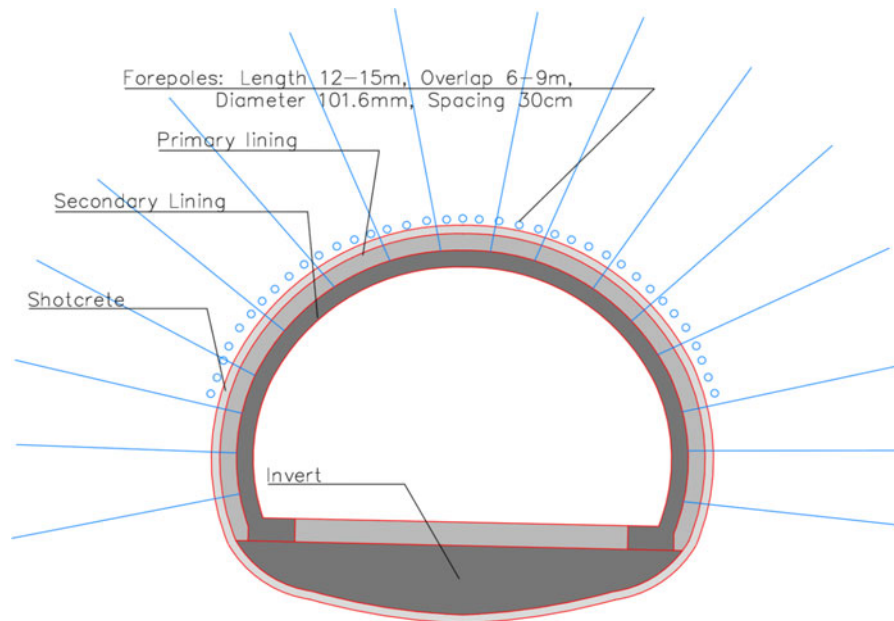

Fig. 22 Details of cross section of the Golovec tunnel (modified after Bizjak and Petkovsek 2004)

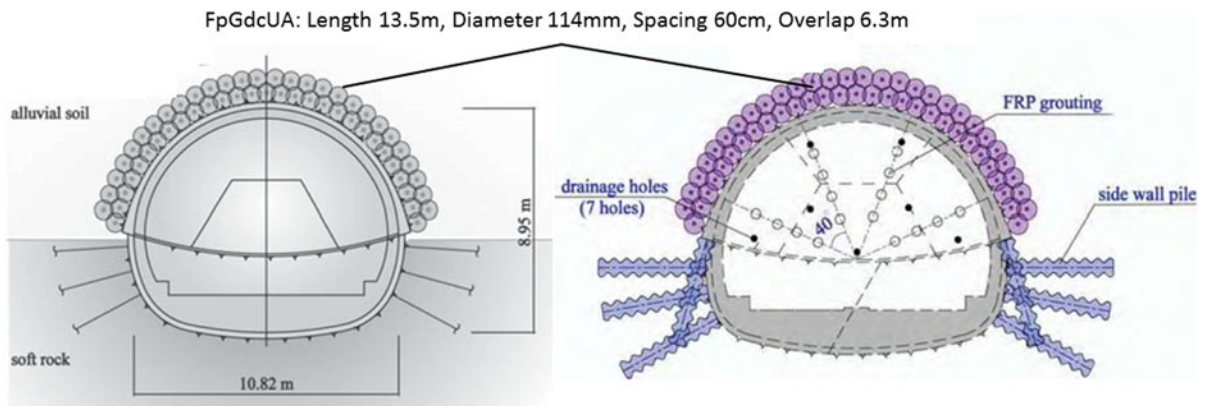

Fig. 23 Ground strengthening techniques and dewatering schema of the Seoul Subway Line 9 at construction site 912 (*Left*) excavation method with jet grouting piles (*right*) dewatering scheme (modified after Kim 2008)

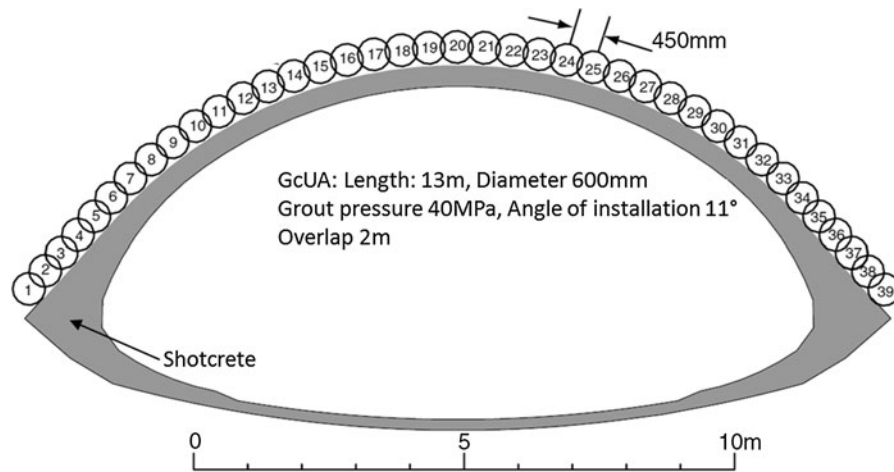

Fig. 24 Top-heading excavation showing jet-grout column numbering at the Aeschertunnel (modified after Coulter and Martin 2006)

13–15.5 m over overburden on the approximately 6 m high heading excavation. If the Aeschertunnel conditions were to be applied to the UASC, it would first require a FpGcUA as there is reference to boulders. Prior to the critical section, subsidence was recorded to be of maximum magnitude of 350 mm. According to the UASC, FpGcUA would yield a reduction of surface settlement of about 93 % (25 mm). A subsidence 25 mm is reasonable as it will only produce low amount of damage to infrastructure according to Attewell et al. (1986).

Nonetheless, the isolated boulders seemed not to be an issue as GcUA was selected for the support. This support was successful in controlling the subsidence by creating a very narrow settlement trough, as well as, a very low volumetric loss of 0.35 %. The GcUA

employed was 13 m long with 2 m of overlap (Fig. 24). The grout columns were 600 mm in diameter, spaced at 450 mm (center to center), and installed at an angle of 11°. The Jet-grouting process utilized had the following installation parameters: 40 MPa pump pressure, a 1:1 grout to water ratio, a 15 rpm drilling rod rotation ratio, a 0.5 m/min withdrawal rate, and a 12 m³/h grout injection rate. For further information on the Aeschertunnel please refer to Coulter and Martin (2006).

7 Discussion/Summary of Findings

Based on Table 3 (generated from the cited literature review) the authors were able to create a generalized

Table 7 Generalized design parameters of the sub categories of the Umbrella Arch

	Umbrella Arch (141)										
	Spile (31)					Forepole (56)					GROUT (15)
	GROUT(1)					GROUT(9)					
	SpCUA (4)	SpGUA (14)	SpGcUA(1)	FpCUA (1)	FpGUA (23)	FpdGUA(2)	FpGoUA (1)	FpGcUA (1)	FpGdcUA (6)	GoUA (0)	GcUA (6)
Length	<H _e	<H _e	<H _e	>H _e (<3H _e)	>H _e (<3H _e)	>H _e (<3H _e)	>H _e (<3H _e)	>H _e (<3H _e)	>H _e (<3H _e)	>H _e (<6H _e)	>H _e (<6H _e)
Angle (°)	5–20	5–20	5–20	3–8	3–8	3–8	6–11	6–11	6–11	6–11	6–11
Overlap (m)	L/3–2L/3	L/3–2L/3	L/3–2L/3	<L/2	<L/2	>L/2	<L/2	<L/2	>L/2	1–L/2	1–L/2
Spacing center-to-center (cm)	<50	<30	<GROUT diameter	<60	30–60	30	GROUT diameter	<GROUT diameter	<GROUT diameter	GROUT diameter	<GROUT diameter
Diameter (mm)	25–101.6	25–101.6	25–101.6	89–168.3	89–168.3	89–168.3	89–168.3	89–168.3	89–168.3	*material dependant	*material dependant
GROUT penetration	NA	0.20–1	35–80	NA	0.20–1	0.20–1	35–80	35–80	35–80	35–80	35–80

XX–XX range of data, XX published cases, H_e height of excavation, NA not applicable, L length of support

design table for each of the individual sub-categories of the UA (Table 7). The generalized design properties included in this table will further aid the tunnel designer in their process of choosing and creating the numerical analysis to verify the chosen preliminary design of the UA, selected from the support selection methodology (or UASC). The support selection methodology (Fig. 8) is intended as an illustrative tool which provides an element of rationalization to the selection of the appropriate UA. The UASC is a quantitative approach of the support selection methodology. As previously stated, however, the UASC is currently based primarily on the TBC (Marinos 2013), which was created from the analysis of 62 tunnels of the Egnatia Odos highway project. Thus, should a tunnelling project fall outside the applicability region of the TBC, so too would the current version of the UASC. Nonetheless, portions of the UASC process have been empirically verified by case studies across the globe and extrapolated in-between verifications. Based on the current progress, it can be established that as the TBC and UASC are further verified around the world, and as the data base for the UA continues to grow, the UASC will increase in applicability.

Another important factor involves surface settlement. Within a numerical analysis, the surface settlement (subsidence management section of the UASC) can be reduced by a factor of 2–2.5, with the addition of bearing capacity of the foundation of the UA (Gioda and Locatelli 1999). Therefore, it can be determined that the selection of the proper UA is not the only critical factor when attempting the reduction of surface settlement. This additional foundational requirement explains why the research of Pichler et al. (2003) found that the employment of a stiffer material below the UA resulted in the reduction of surface settlement by 32 % (compared to no GcUA used), with a difference of 16 % more than their homogenous model (48 % of surface settlement). Therefore, when taking into consideration design parameters, the tunnel designer must also ensure the adequacy of the remainder of the support system, in order to handle the transfer of stress from the UA as well the complex geological conditions.

The authors recommend for numerical analysis that when grout is used solely in a continuous manor in an UA, it can be simplified as homogenous region. This homogenous region is improvement material zone to

simulate the GcUA. This is the only application of the UA that can be modelled in 2D. The process of modelling all other methods as homogenous regions may provide an accurate solution empirically, but not mechanistically (Oke et al. 2012). In these aforementioned cases, the homogenous regions would not capture either the individual arching effect between grout columns (GoUA) or structural steel (spile or Fp), and the longitudinal support interaction.

8 Conclusions

In conclusion, this paper proposes a standardization of nomenclature, a selection methodology for the UA support, as well as, an UASC design tool; one that can be accepted and utilized as a universally applied standard. An extensive collection of literature of support employed at actual tunnel construction sites provided the empirical foundation and substantiation for the proposed nomenclature and the detailed description of each of the sub-categories of the UA. Furthermore, the collection of cited literature provided insight into the development of the selection methodology of an UA, based on the collected geological conditions and stiffness of the support with respect to the impact at the surface as well as stress conditions, water presence and tunnel convergence/behaviour. Overall, this proposed standard addresses the two distinct and often overlooked voids within the field of tunnel engineering within weak rock masses, standardization and methodology of the support utilized as part of the UA support.

Acknowledgments This work has been funded by Natural Sciences and Engineering Research Council of Canada, the Department of National Defence (Canada) as well as graduate funding obtained at Queen's University and the Royal Military College of Canada. The authors would also like to thank Dr. Paul Marinos from the National Technical University of Athens, Greece, for providing the opportunity to visit numerous tunnels under construction in Greece, as well as, Dr. Jean Hutchinson and Dr. Mark Diederichs from Queen's University, Canada for their input and advice as well as providing selected authors the opportunity to visit numerous tunnel projects in Switzerland, France, Italy, and Austria.

Appendix 1

See Table 8.

Table 8 Summary of the terminology of the Umbrella Arch method, elements (3), and sub-categories (11)

Terminology	Definition
Umbrella Arch	A pre-support method that is installed during the first pass of excavation from within the tunnel, above and around the crown of the tunnel face, that reinforces through the interaction of support and the rock mass
Elements	
Spile	A support element of an Umbrella Arch that is metallic longitudinal members that are shorter than the height of the tunnel
Forepole	A support element of an Umbrella Arch that is metallic longitudinal members that are greater than the height of the tunnel
Grouted	A support element of an Umbrella Arch that simply consists of grout
Sub-categories	
SpCUA	A sub-category of an Umbrella Arch, that uses the spile element, which is held in its position through the confinement of the converging rock mass
SpGUA	A sub-category of an Umbrella Arch that uses the spile element, which is held in its position through the employment of grout within the annulus of the element and the overbored rock mass
SpGcUA	A sub-category of an Umbrella Arch that uses a spile element to stiffen the support and to act as a means of access of injection grout to create a continuous layer of grouted rock mass
FpCUA	A sub-category of an Umbrella Arch that uses the Forepole element, which is held in its position through the confinement of the converging rock mass
FpGUA	A sub-category of an Umbrella Arch that uses the Forepole element, which is held in its position through the employment of grout within the annulus of the element and the overbored rock mass
FpdGUA	A sub-category of an Umbrella Arch that uses the a double layer of Forepole elements, which is held in its position through the employment of grout within the annulus of the element and the overbored rock mass
FpGoUA	A sub-category of an Umbrella Arch that uses a Forepole element to stiffen the support and to act as a means of access of injection grout to create columns of grouted rock mass that are not intersecting
FpGcUA	A sub-category of an Umbrella Arch that uses a Forepole element to stiffen the support and to act as a means of access of injection grout to create a continuous layer of grouted rock mass
FpGdcUA	A sub-category of an Umbrella Arch that uses a Forepole element to stiffen the support and to act as a means of access of injection grout to create a double continuous layer of grouted rock mass
GoUA	A sub-category of an Umbrella Arch that uses the grout element to create columns of grouted rock mass that are not intersecting
GcUA	A sub-category of an Umbrella Arch that uses the grout element to create a continuous layer of grouted rock mass

Appendix 2

See Figs. 25 and 26.













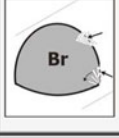

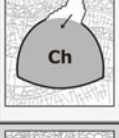

TUNNEL BEHAVIOUR TYPES			
St	Stable ground: Stable tunnel section with local gravity failures. Rock mass is compact with limited and isolated discontinuities		
Br	Brittle failure: Brittle failure or rock bursting at great depths		
Wg	Wedge failure: Wedge sliding or gravity driven failures. Insignificant strains. The rock mass is blocky to very blocky, blocks can fall or slide. The stability is controlled by the geometrical and mechanical characteristics of the discontinuities. The ratio of rock mass strength to the in situ stress (σ_{cm}/p_o) is high ($>0.6-0.7$) and there are very small strains ($\epsilon < 1\%$)		
Ch	Chimney type failure: Rock mass is highly fractured, maintaining most of the time its structure (or at least that of the surrounded rock mass). Rock mass does not have good interlocking (open structure) and in combination with low confinement (lateral stress) can tend to block falls which develop to larger overbreaks of chimney type. The overbreaks may be stopped and "bridged" by better quality rock masses, depending on the in situ conditions. This type may be applied also in cases of brecciated and disintegrated rock mass in ground with high confinement (high lateral stress)		
Rv	Ravelling ground: The rock mass is brecciated and disintegrated or foliated with practically zero cohesion and depending on the intact rock interlocking (Rv1 case: without infilling) and possible secondary hosted geomaterial, (Rv2 case: with infilling, e.g. clay), rock mass can generate immediate rock mass ravelling in face and tunnel perimeter. The difference with Ch type lies in the block size, which is very small here, the self support timing, which is very limited here and the failure extension, where it is unrestricted due to the lack of better rock mass quality in the surrounding zone		
FI	Flowing ground: The rock mass is disintegrated with practically zero cohesion and intense groundwater presence along the discontinuities. Rock fragments flow with water inside the tunnel		
Sh	Shear failure: Minor to medium strains, with the development of shear failures close to the perimeter around the tunnel. Rock mass is characterized by low strength intact rocks ($\sigma_c < 15\text{MPa}$) while the rock mass structure reduces the overall the rock mass strength. Strains develop either at a small to medium tunnel cover (around 50-70m) in case of poor sheared rock masses, or in larger cover in case of better quality rock masses. The ratio of rock mass strength to the in situ stress (σ_{cm}/p_o) is low ($0.3 < \sigma_{cm}/p_o < 0.45$) and strains are measured or expected to be medium (1-2.5 %)		
Sq	Squeezing ground: Large strains, due to overstraining with the development of shear failures in an extended zone around the tunnel. Rock mass consists of low strength intact rocks while the rock mass structure reduces the overall rock mass strength. The ratio of rock mass strength to the in situ stress (σ_{cm}/p_o) is very low ($\sigma_{cm}/p_o < 0.3$) and strains are measured or expected to be $>2.5\%$, and they can be also take place at the face		
Sw	Swelling ground: Rock mass contains a significant amount of swelling minerals (montmorillonite, smectite, anhydrite) which swell and deform in the presence of groundwater. Swelling often occurs in the tunnel floor when the support ring is not fully closed		
San	Anisotropic strains: The rock mass is stratified or schistose or consists of specific weak zones and develops increased strain characteristics along a direction defined by the schistosity.		

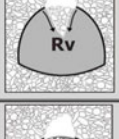
Fig. 25 Brief description and schematic presentation of tunnel behaviour types (modified from Marinos and Tsiambaos 2010) (Marinos 2013). Based on data from Schubert et al. 2003,

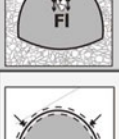
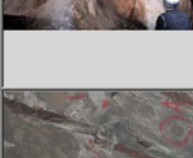
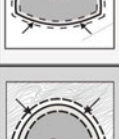
Terzaghi 1946 and from the Marinos (2013). Photos from the author except for "Sq" from E. Hoek (personal communication) and for "San" from Seingre 2005

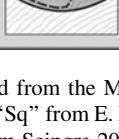
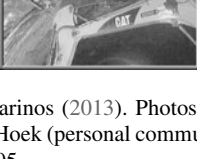
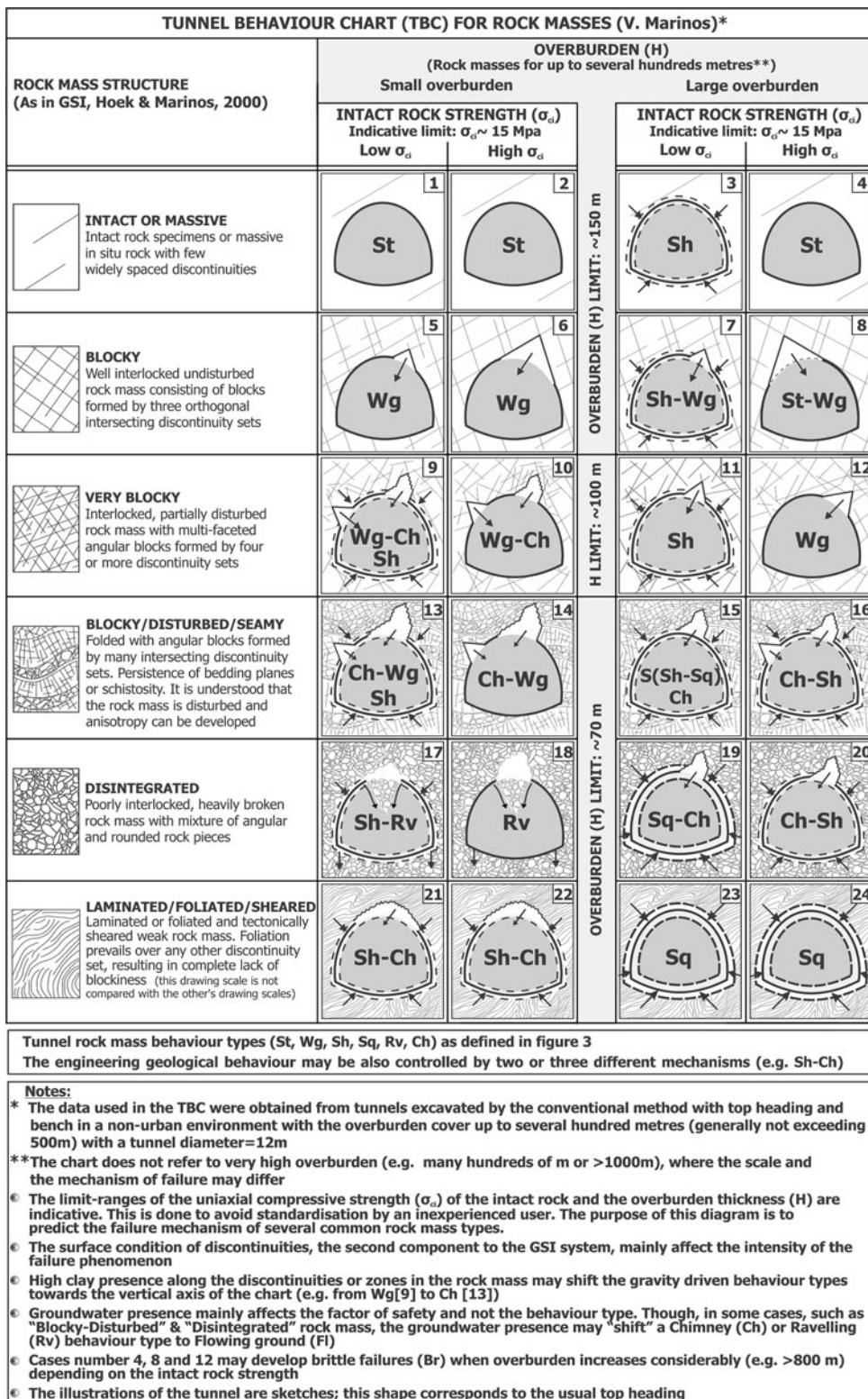

Fig. 26 Tunnel behaviour chart (TBC): an assessment of rock mass behaviour in tunnelling (modified from Marinos and Tsiambaos 2010)

References

- Aksoy CO, Onargan T (2010) The role of umbrella arch and face bolt as deformation preventing support system in preventing building damages. *Tunn Undergr Sp Technol* 25:553–559
- Attewell PB, Yeates J, Selby AR (1986) Soil movements induced by tunnelling and their effects on pipelines and structures. Blackie and Sons Ltd, London
- Bizjak K, Petkovsek B (2004) Displacement analysis of tunnel support in soft rock around a shallow highway tunnel at Golovec. *Eng Geol* 75:89–106
- Coulter S, Martin CD (2006) Effect of jet-grouting on surface settlements above the Aeschertunnel, Switzerland. *Tunn Undergr Sp Technol* 21:542–553
- Croce P, Modoni G, Russo G (2004) Jet-grouting performance in tunneling. *GeoSupport*. American Society of Civil Engineers, Florida
- Dywidag-Systems International (2012) DSI info 19. Dywidag-Systems International. <http://www.dywidag-systems.com/> Accessed October 11, 2012
- Fang Q, Zang D, Ngai L, Wong Y (2012) Shallow tunnelling method (STM) for subway station construction in soft ground. *Tunn Undergr Sp Technol* 29:10–30
- Fasani M, Ammann E, Ruttimann M (2012) Tunnel San Fedele. *Geomech Tunn* 5:135–148
- Gall V, Rudolf J, O'Brien T (2011) Considerations for very shallow conventional (SEM) tunneling in urban settings. Rapid Excavation and Tunneling Conference. San Francisco, California 1281–1296
- Gamsjäger H, Scholz M (2009) Pipe roofing—features and application. 11
- Gibbs PW, Lowrie J, Keiffer S, McQueen L (2002) M5 east—design of a shallow soft ground shotcrete motorway tunnel. In *Proceeding of the 28th ITA-AITES World Tunnelling Congress*, Sydney, Australia
- Gioda G, Locatelli L (1999) Back analysis of the measurements performed during the excavation of a shallow tunnel in sand. *Int J Numer Anal Methods Geomech* 23:1407–1425
- Gschnitzer R, Goliash E (2009) TBM modification for challenging rock conditions—a progress report of the Niagara Tunnel Project (NTP). *Geomech Tunn* (Ernst and Sohn Verlag für Architektur und technische Wissenschaften GmbH and Co.) 2:168–178
- Harazaki I, Anon H, Matsuda A, Aoki T, Hakoishi Y (1998) Field observation of large supported by umbrella method: Case of Maiko Tunnel in Kobe, Japan. *Tunneling and Metropolis*, Proceedings of the world tunneling congress, 1009–1014
- Hoek E (2007) Practical rock engineering. Rocscience Inc, North Vancouver
- John M, Mattle B (2002) Design of tube umbrella. *Mag Czech Tunn Comm Slovak Tunn Assoc* 3
- Keller (2013) Keller: ground improvement. Keller: international geotechnical contractors (2013) <http://www.kellerholding.com/en/services/groundimprovement.html> Accessed 04 13, 2013
- Kim S (2008) Some experience from the soft ground tunnelling in urban ground. Seminar on: the state-of-the-art technology and experience on geotechnical engineering in Korea and Hong Kong. Seoul: Geotechnical Division, the Hong Kong Institution of Engineers, March 28, 2008
- Kimura H, Itoh T, Iwata M, Fujimoto K (2005) Application of new urban tunneling method in Baikoh tunnel excavation. *Tunn Undergr Sp Technol* 20:151–158
- Leca E, Barry N (2007) Settlements induced by tunneling in Soft Ground. *Tunn. and Undergr. Sp. Technology*: 119–149
- Liu H, Shou K, Hou P, Tsai C (2010) Design and construction of river crossing tunnel beneath Tachia River, Taiwan. *Tunn Undergr Sp Technol* 25:638–650
- Lunardi P (2008) Design and construction of tunnels. Springer, Berlin Heidelberg
- Mager W, Mocivnik J (2000) Modern casing technology sets a milestone in drilling and ground anchoring. *Felsbau* 18:43
- Marinos VP (2013) Assessing rock mass behaviour for tunnelling. *Geoscience, Environ Eng* (accepted for publication)
- Marinos P, Tsiambaos G (2010) Tunnels under construction in Greece: tunnel Platanos (In greek). National Technical University of Athens, Athens
- Miura K (2003) Design and construction of mountain tunnels in Japan. *Tunn Undergr Sp Technol* 29:115–126
- Ocak I (2008) Control of surface settlements with umbrella arch methods in second stage excavations of Istanbul Metro. *Tunn Undergr Sp Technol* 23:674–681
- Oke J, Vlachopoulos N, Diederichs M (2012) Sensitivity numerical analysis of orientations and sizes of Forepoles for underground excavations in weak rock. American Rock Mechanics Association, Chicago
- Passlick T, Doerendahi K (2006) Quality assurance in jet grouting for a deep seated slab in Amsterdam, Keller. <http://www.smet-keller.nl/wp-content/downloads/136.publicatie.Jetgrouten.Amsterdam%203%20stations.engels.pdf> accessed 2012
- Peila D, Pelizza S (2003) Ground reinforcing and steel pipe umbrella system in tunnelling. In: Kolymbas D (ed) *Rational tunneling: advances in geotechnical engineering and tunnelling*. Logos Verlag Berlin, Innsbruck, pp 93–132
- Pichler C, Lackner R, Spira Y (2003) Thermochemomechanical assessment of ground improvement by jet grouting in tunneling. *J Eng Mech* 129:951–962
- Sadaghiani M, Dadizadeh S (2010) Study on the effect of a new construction method for a large span metro underground station in Tabriz-Iran. *Tunn Undergr Sp Technol* 25:63–69
- Schumacher FP, Kim E (2013) Modeling the pip umbrella roof support system in a Western US under ground coal mine. *Int J Rock Mech Min Sci* 23:114–124
- Shin CB, Chum BS, Park D, Jung JJ (2006) Construction of double track subway tunnel in the alluvial soils with shallow overburden. In: Proceedings of the ITA-AITES 2006 World Tunnel Congress and the 32nd ITA General Assembly, Seoul, Korea
- Song K, Cho G, Sim Y, Lee I (2006) Optimization of a pre-improvement support system for large underground excavation. *Tunn Undergr Sp Technol* 21:374
- Trinh QN (2006) Analyses of a cave-in problem in a hydro-power tunnel in Vietnam. Dissertation, Trondheim, Norway: Norwegian University of Science and Technology
- Trinh QN, Broch E, Lu M (2007) Three dimensional modelling of spiling bolts for tunnelling at weakness zones. In: Eberhardt E, Stead D, Morrison T (eds) *Rock mechanics:*

- meeting society's challenges and demands. Taylor and Francis, London, pp 427–432
- Tuncdemir H, Aksoy CO, Guclu E, Ozer SC (2012) Umbrella arch and forepoling support methods: a comparison. *EU-ROCK*, Stockholm, pp 515–527
- Vardakos S (2007) Back-analysis methods for optimal tunnel design. Dissertation, Blacksburg, Virginia: Virginia Polytechnic Institute and State University
- Vlachopoulos N (2009) Material behaviour and near-face support issues associated with the tunneling through weak rock masses. Dissertation, Kingston, Ontario: Queen's University
- Vlachopoulos N, Diederichs MS (2009) Improved longitudinal displacement profiles for convergence confinement analysis of deep tunnels. *Rock Mech Rock Eng* 42(2):131–146. doi:10.1007/s00603-009-0176-4
- Vlachopoulos N, Diederichs MS, Marinos V, Marinos P (2013) Tunnel behaviour associated with the weak Alpine rock masses of the Driskos twin tunnel system, Egnatia Odos Highway. *Can Geotech J* 50:91–120
- Volkman GM, Schubert W (2006) A contribution to the design of tunnels supported by a pipe roof. American Rock Mechanics Association, Golden
- Volkman GM, Schubert W (2007) Geotechnical model for pipe roof supports in tunneling. In: Proceedings of the 33rd ITA-AITES world tunneling congress, underground space—the 4th dimension of metropolises. Prague: Taylor and Francis Group 755–760
- Wang H (2012) Optimization of pipe roof reinforcement applied in tunnel construction under complex conditions. *Electron J Geotech Eng* 17:301–310
- Warner PE (2004) Practical handbook of grouting. Wiley, New Jersey
- Wittke W, Pierau B, Erichsen C (2006) New austrian tunneling method (NATM)—stability analysis and design. WBI, Essen
- Yasitli E (2012) Numerical modeling of surface settlements at the transition zone excavated by New Austrian tunneling method and umbrella arch method in weak rock. *Arab J Geosci* 6:2699–2708
- Yeo C, Lee F, Tan S, Hasegawa O (2009) Three dimensional numerical modelling of a NATM tunnel. *Intern J Jpn Comm Rock Mech* 5:33–38